

## 2 Laws of Engineering System Evolution

### 2.0 Introduction

Do you know why people sometimes solve their problematic situations in the wrong way? Not only schoolboys and students, but also designers and engineers, directors and writers, presidents and even Kings can solve their problems in the wrong way? Probably, you can recollect some examples of wrong solutions, as well as some examples of creative solutions.

To find the answer to this tricky question, we will offer you a short 33-seconds travel in the company of Antoine de Saint Exupéry and the Little Prince to an asteroid № 325 in order to visit the King...

The king ruled over all – his small planet, the other planets and all the stars... And all surroundings obeyed him. The Little Prince has been admired by such power! And he has also asked the King to order the Sun to set because he liked very much to admire a sunset.

-«I will order the Sun to go down», – answered the King, «but, at first, I will wait for favorable conditions because the wisdom of a king includes careful consideration. »

«And when conditions will be favorable? » – asked the Little Prince.

- "Hum! Hum!" replied the king; and before saying anything else he consulted a bulky almanac. "Hum! Hum! That will be about--about--that will be this evening about twenty minutes to eight. And you will see how well I am obeyed!"

You should not doubt, the Sun went down exactly at 07:40 p.m. because it is one of the laws of Nature. And the King was really wise because he behaves in accordance with the laws of nature and did not break these laws.

Our world consists of paradoxes. And the most surprising of them deals with the fact that people at all times looked for the connection of various processes and phenomena. Even there, where there is no connection! However, it is not the case because a new researcher comes and detects this connection.

Laws, i.e. interrelations of processes and phenomena in nature form the basis of knowledge about the world which surrounds us and which is important not only in diverse sciences, but also in our daily, ordinary life. A simple example illustrates this. Any driver knows if a road is wet after the rain, the length of the break path increases.

For what purpose do we need knowledge about the laws of nature? It is necessary for a person to look constantly in the future for the purposeful and intelligent activity. At least, to look one step forward. Recollect, even simply walking in a park you unconsciously look for space on the ground for your next step. The more difficult the way is, the more attention it demands. The more difficult the system is, the greater efforts are necessary to forecast its development. And only if we have defined the laws according to which systems develop, it is possible to say with confidence about the further step of development of this or another system.

### 2.0.1 The role of the Laws in TRIZ

#### 2.0.1.1 Laws in science

Any science becomes a science in a full sense only when it starts describing the world on the basis of the laws which are discovered by this science. The astronomy became the science, when it discovered the laws of movement of planets. The alchemy became chemistry, when it described the laws of interaction and transformation of substances.

TRIZ – the science which studies processes on the boundary of two objects: a person and technology. The sphere of its studying includes both thinking of a person as well as the laws of evolution of technical systems. Any theory has a fundamental character, but it also develops its

applied tools. TRIZ develops tools for solution of creative problems, ways of narrowing of a search field, methods of conscious management of unconscious processes.

One of typical mistakes of TRIZ studying and teaching consists in that TRIZ is studied as another subject: as physics, chemistry or astronomy. The center of studying in these sciences is the surrounding world, the natural phenomena, whereas in TRIZ the more attention should be given to the processes of thinking.

## 2.0.1.2 Laws in TRIZ

The laws of development of technical systems were firstly published by G. S. Altshuller in his book *Creativity as an Exact Science: the Theory of the Solution of Inventive Problems* in 1979:

1. The law of the completeness of parts of the system.
2. The law of “energy conductivity”.
3. The law of harmonizing the rhythms of parts of the system.
4. The law of increasing of the degree of idealness of the system.
5. The law of uneven development of parts of a system.
6. The law of the transition to a super-system.
7. The law of the transition from a macro to a micro level.
8. The law of increase of the S-field involvement.

If to speak about TRIZ as about the system, it is important to mention that it is very harmonious. The tools which are included in its structure make the system work. They are interconnected, and the basis is formed by the Laws of Development of Technical Systems.

Laws are divided into 3 groups: laws of statics (1-3), laws of kinematics (4-6); laws of dynamics (7, 8). In such a division there is a certain analogy with mechanics – the section of physics. By consideration of «a life line » of development of the technical system *the S-shaped curve*, the following is observed. The Laws of statics are characteristic for the appearance stage of the technical system; laws of kinematics – for the development stage of the technical system; laws of dynamics – for the closing stage of development and transition to a subsystem. The technical system develops and changes. The model of the technical system changes as well. The new assumptions appear which are considered in accordance with a concrete situation with the aim of constructing a model.

Thus, while calculations of the flight speed of the plane from one point to another, the plane is considered to be a material point. But, while defining the minimal speed which is necessary to fly up, we shall take into consideration an absolutely different situation, other physical laws. The lifting strength will raise our attention. It effects wings of a plane and also its weight. During calculations of a maximum admissible speed for a safe landing we shall deal with absolutely different objects. It is very important to define the aim and to select an appropriate model.

## 2.0.1.3 The Characteristics of laws of development of the technical system at its different stages of development systems

At the appearance stage, during the creation of a new technical system the system is studied as "an object in itself". The most important processes essential to its ability to survive occur inside of the system. In this case, the assumptions are possible and the system is studied separately from another surrounding technical systems. The following questions are solved for the system: « To be or to not be? », «What kind of structure should be used? » By analogy with mechanics: in mechanics, the laws of statics study a balance condition of a material body under the influence of the applied forces.

At the development stage of the technical system evolutionary processes are studied in the technical system, but irrespective of the technical and the physical factors which define this development. The processes which define the development are still found inside of the techni-

cal system. But the main thing is not any more the survival of the technical system, but movement, development, achievement of the certain level in comparison with other technical systems. The most essential at the given stage is the achievement of the maximal values of key parameters by the technical system. These key parameters include speed of a plane; a carrying capacity of a car, a number of operations per second produced by a computer.

At the closing stage of development the laws of transition to new systems come in the foreground. Actually, resources of development of the technical system are outspent. The existing system is studied in an environment of other technical systems. The main question is « How to encourage development in an existing environment? », while it is examined under the influence of concrete, technical and physical factors.

#### **2.0.1.4 The definition of laws of development of technical systems in the given textbook**

The system of laws of development of technical systems is also developing. The works of many researchers and developers have specified and enlarged the tools of the applied laws. Let us mention the names of some researchers in this area: Altshuller G.S., Zlotin B.L., Petrov V.M., Litvin S.S., Vertkin I.M., Fey V.R., Lubomirski A.L., Salamatov Y.P., Kondrakov I.M. and many others.

There are several systems of laws of development with its characteristics, specifications and hypothesis in TRIZ. Serious research is conducted in each of these systems. There exist disputable positions in some publications, but this is the consequence of the research process and development. All of them anyhow lean on the classical system of Laws of G.S.Altshuller. That is why we study this system.

In the given material, we adhere to the classical system of Laws Engineering Systems Evolution – the system of G.S. Altshuller. Basically, such a choice is determined by the educational purposes of materials. These are 8 laws, each of which is described in a separate chapter. It is possible to begin the introductory reading from any of them. However, it is more logical and effectual to study the materials in succession starting with the first chapter.

Each chapter has following sections: Definitions, Theory, Model, Tools, and also includes questions for self-tests.

At the end of each chapter the list of the applied literature is given. We tried not to use other examples from other books and articles which deal with TRIZ in these materials. A great number of schemes, pictures and photos are used in the texts in order to illustrate the presented material.

We wish you a pleasant and effective reading and creative, royal-wise solutions!

## 2.1: The law of the completeness of parts of the system

In Paris Museum «Arts et Métiers», in the grand staircase under the ceiling, a flying machine constructed by a French inventor, Clément Ader, soars. In 1890 this flying machine managed to make a short flight at the height of several centimetres. It may make you smile now, but it was indeed a big breakthrough at that time!

Can it be seen as an airplane? How technically viable was the construction in years of its building? Who and what country is the founder of the first aeronautic vehicle? What mistakes did the first aviators make?

Let us quote the American Professor, Samuel Langly who dealt with the theory of aviation. When he was asked why the first aviators had had failures, he answered: “Perhaps, because man came up to the issue from the end and tried to make flying machines before he learnt the laws on which flying is based on”.



Prototype of the Avion III de [fr:Clément Ader](#). Musée des Arts et Métiers, Parigi (Source: [www.wikipedia.org](http://www.wikipedia.org) , Photo et photo-montage © [Roby](#) )

Before trying to answer the questions mentioned above and not only those concerning flying machines, but also any other technical systems, it is necessary to know and be able to apply the Laws of Engineering Systems Evolution.

### 2.1.1. Definition

“A necessary condition for the living capability in principle of technical systems is the presence and minimal functioning power of the basic parts of the system.”

Altshuller, G. S. (1984). *Creativity as an Exact Science: The Theory of the Solution of Inventive Problems* (A. Williams, Trans.): Gordon and Breach Science Publishers.), p. 223.

#### The consequence:

“For a technical system to be controllable it is necessary for at least one of its parts to be controllable.

“To be controllable” means changing its properties in a way required by the controller.”

Altshuller, G. S. (1984). *Creativity as an Exact Science: The Theory of the Solution of Inventive Problems* (A. Williams, Trans.): Gordon and Breach Science Publishers.), p. 224.

The law is related to the chapter “Static”, to be more precise, to the laws which define the life beginning of technical systems.

However, it is important to understand that the law refers not only to such ancient technical systems as a bow, a stone axe, a catapult. Any technical system changes during its evolution. There is very often a full replacement of one or several basic parts in the technical system. At the moment of such a change of parts a new system actually appears and the law of the completeness of parts of the system is applicable to it as well as for the essentially new technical system.



## 2.1.2. Theory

### Details

Any technical system consists of certain parts (taking a look at the technical system we can distinguish its parts). A pen consists of a case, writing bar and an end cap. We use such a description to give a more detailed description of the device of the technical system and have a better understanding of the operating principle of this technical system. This is a model of the system which is given in the components of its subsystems.

There are a lots of system models.

For instance, a picture of the airplane, a picture of the automobile, an electronic scheme of a telephone; a spoken story about what a computer is; a textual description of glasses – all this are models of different technical systems.

The model used in the given law determines the main parts of *any* technical system from the point of view of its functioning and evolution. The main aim of the given model is its use during a problem solution. This model is constructed with the definite aims, for example, a device photo gives the general view about its appearance or component drawings describe its integral parts. The model will become good, if it allows achieving the stated aims and gives answers to the posed questions. For example, the aerodynamic model of a car is used to solve the problem of a decrease of wind resistance.

The purpose of the given model is to generalize all technical systems and to show the most general peculiarities of the technical system.

The minimum working capacity of parts of the system is an ability of parts of the system to provide teamwork in order to perform the basic function of the technical system. The criterion of the function's performance is the change in the element's parameter values. (During the description of the function in terms of the OTSM – ENV model).

The minimum admissible change of a parameter value is caused by requirements of the consumer of the given technical system. The information about the algorithm which defines the function is described in the part of this chapter: Tools à How to determine a function of the technical system correctly.

For example, the function of a car: to change a location (N = Name of the Property) of the person (E = Element) from the house (V1 = Value 1) to the work (V2 = Value 2). If the essentially new model of the car can drive a person only some metres (to change the location of the person), it is obviously not enough for the consumer. Hardly, someone will buy such a car. But it can quite satisfy the designer at the given development stage of this car.

Differently, the given technical system possesses necessary conditions for its life capability. It contains the basic parts according to the four-element model. These parts have minimal functioning power in its structure.

### The typical mistakes

Often the connection between the law and its consequence seems to be not obvious. It is important to understand the logic of a consequence about controllability and its connection with the law. The controllability is explained in more detail in the consequence of the law. Controllability is understood as the possibility to change value of a parameter or parameters of the technical system and its parts during its operational time. Each part of a technical system works in one "organism" and is used with the aim of achieving the general function. Due to, it is possible to operate the whole system by operation of one of its parts. It is fair to say the opposite. If it is not possible to operate any of the basic parts of a system, the whole system is not operational (i.e., we cannot change value of parameters of one of parts in order to change parameters of the whole system).

## 2.1.3. Model

A model includes the main parts of the technical system: the engine, the transmission, the tool, the control unit. (The main parts of the technical system are separated in the scheme by a dashed line). In a general case, the source of energy and an object do not form any part of the technical system. For instance, the water stream in a river that brings the mill wheel into motion or the wind that makes blades of a wind electrical power station rotate. However, *Source of energy*, «batteries» of the technical system, «flashlight» are included into the technical system. The engine and energy source are often the same, but not always. Further on, we consider the example of four elements model in more detail. First of all, we will begin with the function definition of the technical system.

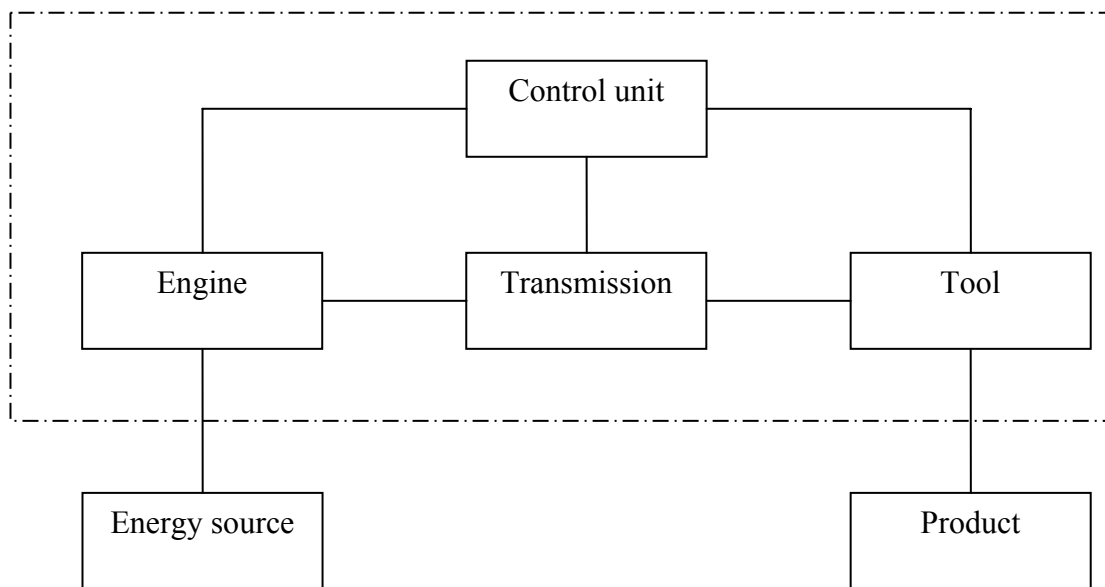

Fig. 1.3. The main parts of the technical system

## 2.1.4. Tools (how to use)

### 2.1.4.1. How to determine the function of the technical system correctly

The function of the technical system should be defined before we can use the law of the completeness of parts of the system in practice. It is a very important moment.

The function is found in the aim of the system existence, to be more precise, with what aim we will use the system. When we have no distinct idea about a function, we can not define the composition of the system in accordance with a four element model. To talk about a system in this case does not make any sense.

### Some preliminary notes

\*) this technical system could be represented by diverse models with the aim of fulfilling diverse functions.

\*\*\*) it should be noted that the analogical situation can occur during the analysis of the multi-screen scheme. If the function is not defined, we will come to nonsense during the analysis. Not determining the function of the technical system it is not possible to discuss the structure of the system according to the OTSM-TRIZ theory.

## The structure of the system

It should be noted what we understand under the structure of the system. It is the composition of its components in the system and the complex of interconnections in the system, as a result of which the quality appears, which we also call « the function», with the help of which we reach the formulated aim. All that functions in order to improve the quality are the components of the system. But other phenomena, which do not function, do not define the components of the system, even if these elements are located in the system. On the other hand, the elements, which are located far away from the system and do not have any relation to it, often form a part of the system, if the function is defined. To be more precise, if we define the function correctly, we often form the new vision of the technical system and discover previously unnoticed interconnections. It is one of the main goals of the analysis. To be more precise, we form the model of the minimal system with the defined function.



## The algorithm of the definable function consists of three steps.

(Common language model of Function). A person explains with his words what he wants to get from this system. In the process of studying students come quickly to the second step. But there are also cases as well, when it is not easy to reach an agreement about the oral description of the function. In order to come to the agreement, we need the second step.



1. (Verb-Noun model – Value Analysis model). It is the model of *Universal Semantic Code (USC)*, and the model of Value Analysis. In practice several verbs often appear during the analysis of the function of the technical system. It is especially characteristic for the complicated systems. A noun usually describes a product, which will be changed. And a verb characterizes the way the product changes. This approach is good for the functional analysis, it is much better to use this approach than to apply the oral model using the universal language. But the following problems may appear: the existence of verbs-synonyms. Each of them causes its own association and the psychological inertia appears which prevents from solving a problem. Our experience show that in many cases this model (Verb-Noun model – Value Analysis model) leads to the deadlock or can lead into the false direction.
2. Four verbs ENV Model – OTSM ENV model of Functional Description. ENV Model allows performing a deeper analysis and describing a function of the technical system in more detail. There are also possibilities to develop and to improve this model and it is better than the Verb-Noun model. We should use four verbs and describe the function using the terms of the OTSM – ENV Model.
  - 3.1. First of all, we should define the „Element“. During the second step we defined the verb and the noun. The noun is an element, to be more precise, the product. If we need another element during the transition to the third step, it means that we have defined it in a wrong way. In this case it is necessary to return back to the second step and to concretise the Verb-Noun model. A verb describes the change of something, while the function is the change of something. There are four types of verbs, four types of changing something: «to change», «to decrease», «to increase» (these are the varieties of change, but sometimes it is important to concretise the change) and the fourth verbal type– «to keep». When we talk about management/control, we need to «change», to be more precise, we use the dual change – to decrease and to increase.
  - 3.2. What do we change particularly? What does it mean «to change the element E»? We change the certain parameter of this element – N, “Name of the parameter”.
  - 3.3. How do we change this parameter? We change the meaning of the parameter:

“Value of the parameter”. During the description of the model we should indicate: «the change of the value of the parameter N of the element E with the value V1 to the value V2». For example, the change of the value of the half-finished product, raw material changes the value of the product. We have at least one parameter.

Notes:

\*) Actually, it is necessary to mention that one function performs the change of one parameter. If we have several parameters, it means that we have several functions, and it lead to the conclusion that we have several folded systems.

That is why, except three listed verbs there is also the fourth: „to keep“ – to keep, not to change. Actually, it is a purely psychological trick in the course of training. It is often easier for a student to say the verb «to keep» instead of «not to change». A typical example which we use in the course of training - what is the function of a bottle? To keep water. According to the definition, the function always represents some kind of the change. If we have faced with the verb «to keep», it means that we have faced with the psychological inertia. The verb “to keep” serves as an indicator for some deep processes, which we should understand. If we say «to keep», we should think over the following step, what we should change in order «to keep». (To prevent undesirable changes and «to keep» the current state).

Let us illustrate one of the typical examples in order to define the function of the technical system and to understand **what should be changed**. In order to understand it better, within the limits of the concrete, described situation, one should do a mental experiment – take away an object. There is a bottle with water on a table. Our aim is to define the function of the bottle. Mentally, we will take away the bottle (but not water!). What will happen? Water will flow... Why? Since gravitation forces exert influence on this process. Therefore, the function of the bottle is to compensate, to change and to correct the influence forces of gravitation. Its function is to prevent and to change water flow.

This algorithm allows performing the deeper analysis, to formulate the function more precisely and to define the parts of the system.

## The example

Let us consider the traditional application of the car which transports people and cargoes.

### The first step (Common language model of Function)

Cars are usually used to transport people and cargoes from one place to another. We will not consider now other functions of the car, for example: it can serve as a shelter from a rain, to measure distance between two points. It can serve as a warehouse for old things and it has many other functions (this topic is more appropriate for the course of developments of creative imagination)



### The second step

An object, a product: a person. The function: to remove a person, to transport him.

### The third step

E – an element: a person; N – the name of the parameter: the location of a person; V the value of the parameter: V1– from a house; V2 – to work.

The function of the car: to change the location (N) of a person (E) from home (V1) to work (V2).

ENV Model: E – “Element”; N – “Name of the parameter”; V – “Value of the parameter”.

## 2.1.4.2. How to determine the parts of the technical system correctly

### Some preliminary notes

\*) The typical mistake is that before the definition of functions of the system, we try to define



its main parts in accordance with a four elements model. That is why in this case, the analysis of the technical system which defines its main parts represents the subjective point of view: “It seems to me so, I see it in such a way.”

## The Product

When we define the function, we will define the Product automatically. It is defined as the change in the process of the function fulfilment. The tool is the part of the system which interacts with the product. A cutter of the lathe tool, not the lathe tool itself, a knife edge, not a knife itself. We need energy of some special type in order to fulfil the function (the change of the material object). That is why we need an engine. The engine is the part of the system which transforms the accessible energy type into the necessary form for a tool to fulfil the function. Transmission includes parts of the system which transforms the accessible energy type to the Tool from the Engine.

\*) We use the concept «product» with the meaning of a product, an object which is ready to be used in our every day life. From the common point of view, raw vegetables which are cooked in boiled water for some time are ready products which can be eaten. The more effective models suggested in OTSM-TRIZ are used for the situation analysis with the aim of solving a problem. The thing which we call the Product is not an end product, but the Transformation of the half-finished product (Product 1) into the product which is ready to be used (Product2) in another system or to be applied by people. In this particular case, we examine the Product in terms of the multi-screen scheme, along the time axis. The product 1 shows its qualities before the change and product 2 after the change.

So, we have the Product 1 during the initial moment. Under the influence of the Tool, we receive another Product during the completion of the Function. And as a result of the process, we receive the Product 2 which is ready to be used. So, there are at least three screens on time axis in the multi-screen scheme. All three screens are included into «Product» which aim is to fulfill the function. During the function fulfilment the intermediate product step by step transforms into the product which is ready to be used in another system or to be applied by people.

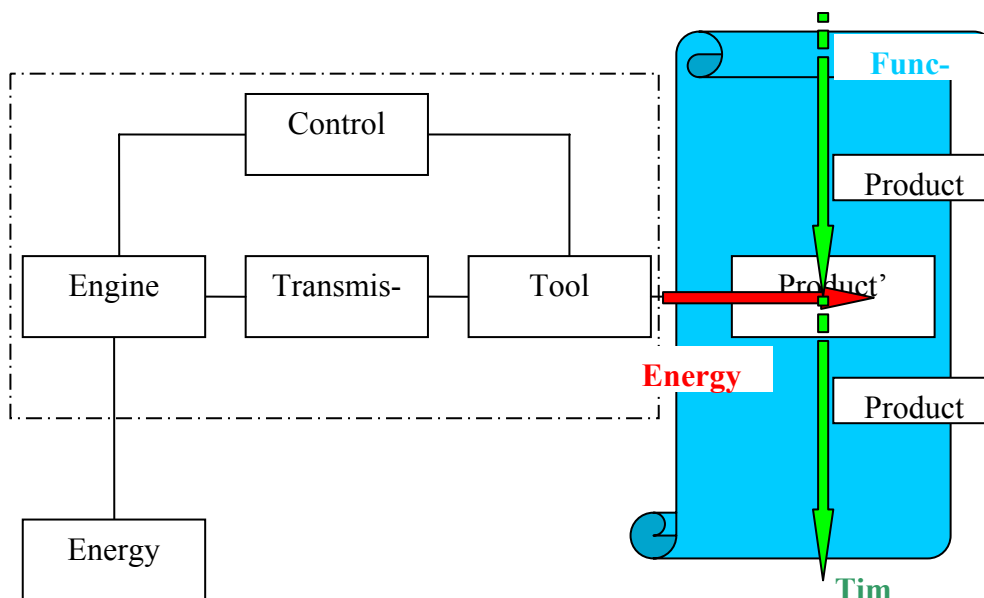

Fig. 1.4. Transformation of Product 1 into Product 2.

## The typical mistake

Usually, all can give the definition of the multi-screen scheme. But in practice, when we discuss the Product, it is difficult to understand, because it is necessary to see all in development, in movement.

## The Tool

Further on, if it is necessary to change something, at least one parameter will change the value. If we have the material system, we should usually change a material object in order to change the value of a parameter. Even if we change the location of an object, energy is demanded. There is something that makes this change. We call it the Tool. The Tool is something that cooperates directly with the Product.

In the example with the car: the Product is a person. It is necessary to change the location of the Product. What change the location of a person? Not a car, but that part which cooperates with Product directly. It is the seat.

Altshuller, G. S. gives the classical example: the Tool is not the lathe, but a cutter of the lathe tool. In case, when you cut an apple with a knife, the Tool is not the knife, but the knife edge. It is very important nuance.

## The Engine

As soon as we have defined the Tool, we return to the question about energy. We need to spend energy in order to change any parameter of a material object. Accordingly, it is necessary to understand what kind of energy we should spend. (What kind of energy is involved during the completion of the function?).

Let us consider not only the presence of through pass of energy, but also a chain of transformations of various kinds of energy.

In the example with the car:

It is necessary to transport a person from one point to another, this is linear movement. If we spend kinetic energy for this purpose, we should receive it from somewhere. We need linear kinetic energy in order to transport. We should find a place, where linear kinetic energy appears in a car and how it reaches the Tool. It is necessary for us to define the engine, (not the physical engine of a car, but to define «Engine» in accordance with the classification of four elements model).

\*)

Let us notice that the engine of a car can be: the steam-engine, the internal combustion engine, the diesel engine-motor, the engine of String, the mechanical converter on the basis of a spring or rubber; the jet stream of a liquid or a gas; the untwisted flywheel (as in children toys) and many other things...

\*\*)

In the previous paragraph we discussed the part of a car which we call an engine in our everyday life. What can be an engine in a traditional car in terms of four-element model taking into account diverse situations? It is not necessarily a car motor. For example, barrels filled with air, the so called «pontoons» can be «engine» as well which are used to perform the function «to raise the sunken car from the river bed to the surface».

When we talk about «Engine» within the frame the OTSM-approach of a problem solution, we talk about the last converter of energy from some form (primary energy of «Energy source»), which is accessible to the given system. This energy is transformed during one or several steps of transformation to that kind of energy, which is necessary for the «Tool». There is a chain of transformations and we choose the last transformation, as a result of which we receive energy, which is necessary to fulfill the function. The boundary of the minimal technical system is there, where the energy transmission takes place from one type into another one which is necessary for the Tool in order to fulfil the function. This moment is of special importance for the situation analysis, when it is necessary to find an explanation for unclear and undesirable effects.

## The Transmission

Transmission includes all elements (subsystems) of the whole technical system through which energy is transformed without any change of its type. Energy is transformed from the engine to the tool. It is necessary to mention that this process is of special importance during the research of causes of unclear effects.

The schematic algorithm which defines the components of the minimal technical system is represented below:

1. Function. OTSM-algorithm.
2. Product.
3. Tool.
4. Engine.
5. Transmission.

### 2.1.4.3. How to estimate the working capacity of parts of the technical system

1. Presence of four parts in a system.
2. Working capacity of each part out of a system
3. Working capacity of each part as a part of a system
4. Estimation in accordance with other developed laws of technical systems.

### 2.1.4.4. How to estimate the operation of parts of the technical system

1. Control presence – Do we have such a controlled part in a system?
2. What is the degree of controllability of other three elements? (To estimate: do they cope with the task good or badly).
3. What management parameters do we have?

### 2.1.5. Example (Problem-Solution)

#### Example The conditions of «Engine» incapacity.

Let us consider the following function of a car on the basis of a combustion engine: “To move itself from one place into another”.

*Let us put a question: Under what conditions the car will not fulfill its function, will not move and transport itself and cargoes?*

It is possible, in the case, when one of its parts of four elements model is absent: «Engine», «Transmission», «Tool», «Control Unit». What does it mean?

If «Engine» is absent or incapable: for example, on the Moon. The matter is that air oxygen, which is not present on the Moon, is necessary for functioning of the internal combustion engine. The cause of incapacity of «Engine» - absence of one of parts of «Energy source»: petroleum + air oxygen.

We will illustrate one more example. We need not pure petroleum for the engine, but a mixture of petroleum with air oxygen in a certain proportion. Very small drops of petroleum in air – a petrol fog which prepares one of the units of «Engine» - the carburettor.

Notes:

It is very important to analyze the whole chain of energy transformations, functioning of the technical system and its structure in detail in order to analyze the technical system and to solve a problem.

The engine will not function, if we fill in petroleum in the cylinder. If we change the quality of fuel in such a way that fog can not be formed, as a result, fuel can not be burned down and the engine can not transform the chemical energy of fuel into the mechanical energy of moving pistons. In one detective film the hero pours ordinary sugar in a petrol tank in order to elimi-



nate the chance of his persecutors to drive the car and to catch him. The received «petrol syrup» has other properties, for example, its viscosity. In this case, the necessary fuel for combustion is not available— a fog will not be formed, the engine will not start, the car will not be driven. (We do not recommend repeating this experience, because it can destroy the whole engine).

## Example



The car can not fulfill the formulated function, for example, in case of absence or incapacity of «Transmission». «Transmission» - a part of the technical system, which transform energy in the form of its «Engine» transformation with the aim of supplying it to «Tool», in this case, mechanical energy (rotations). As a result of fuel combustion in cylinders there is a back and forth motions of pistons in the traditional internal combustion engine. If simply to transfer this movement (as movement of a swing: «forward-backward») on wheels, the car will not move. It is necessary that the transformation of one kind of mechanical energy into another takes place and as a consequence, the movement of pistons will lead to wheel rotation. For this purpose, there is the number of transfer mechanisms in a car. These are drive shaft, gear wheels, couplings...

## Example



The car can not perform the formulated function («To move itself from one place into another») for example, if the «Tool» is absent or is broken. The wheel pushes the car from a road surface. For example, a wheel can not make a start on the absolutely slippery road. The friction, a coupling of a wheel with a road is necessary in order to bring the car into movement. The standard car, which is capable to float on water, cannot move along a river or lake. In this case, we need another operating device, for example, special wheels with blades or the water propeller like on the ship.

In the photo below, “Amphicar” is illustrated. Its Tools during its movement on water (according to the classification of four element model) are two middle-sized propellers.

## Example



The car also can not normally perform the function, if the «Control System» is absent or broken. «Control System» usually includes steering, brakes, a rearview mirror. But firstly, it is necessary to provide the operative work of «Engine». It is not enough to fill in «a petrol fog» in cylinders, it should be transported in the definite moment, not earlier and not later on; It is necessary to ignite it, to be more precise, to ignite a spark in that moment, when «a petrol fog» is supplied in a cylinder. It is necessary to release the formed exhaust gases from the cylinder. In most cases, it is «programmed» in the operational system of an engine; a driver himself can control some operations.

## Example



And as a final example we illustrate a humoristic view of the car of the Stone Age. How did it look in the past? There are wheels and the engine, the case and the cabin for a driver...But this car will never be able to fulfill the characteristic function of cars: «to transport people or cargoes from one place to another». This can not move itself. Any of its parts is not able to operate separately or as a part of a system.

## 2.1.6. Self Assessment - Questions, tasks

1. What difference do we have between the technical system and other technical objects?
2. What parts are included in the composition of four element model of the technical system?
3. How can you define «the law of the completeness of parts of a system»?
4. What condition is necessary for the existence of the controlled technical system?



### Summary.

We can imagine any technical system as a model which consists of four main parts – Engine, Transmission, Tool and Control Unit.

The technical system will be operative, if it includes the mentioned, minimum-operative parts.

### The Basic definitions.

Technical system; function of the technical system; Model; sub-system; evolution; engine; transmission; Tool; Control unit; Product; S-curve.

## 2.1.7 References

1. Altshuller, G. S. Creativity as an exact science. — M.: Soviet Radio, 1979. (Russian), Page 123.
2. **Altshuller, G. S.** (1984). *Creativity as an Exact Science: The Theory of the Solution of Inventive Problems* (A. Williams, Trans.): Gordon and Breach Science Publishers.). Pages: 223-224.
3. **Salamatov J.**, System of development of creativity laws. /In book: «Chance of adventure»/ Copiler. A.B. Selutsky. – Petrozavodsk: Karelia. 1991. (Russian). – Pages 62-67.
4. **Khomenko N.**, "Handbook for “Advanced Master in Innovative Design” course. Strasbourg, (2003-2009).
5. **Khomenko N.**, “The law of the completeness of parts of the system” with OTCM-TRIZ interpretation. Karlsruhe, 2008. (Russian, manuscript, 09.07.2008)



## 2.2 The law of ‘energy conductivity’ of a system

According to the German traffic rules a bicyclist should have a headlight and a tail light behind during movement at night. And, the basic energy source for these devices **should be necessarily a dynamo-car**, instead of batteries, accumulators or, especially, solar batteries according to rules. Why? We will notice that many rules and laws as some lawyers say «are written by blood». To be more precise, a wide experience of many people is concentrated in them, both negative experience, and ways of overcoming of problematic situations. To say it differently, objective laws, recommendations about their performance and a payment for possible errors are described in them.

Let's return to a bicycle. To be more precise, to the system of the signaling and the illumination.

The device of illumination of road on a bicycle is the most important at night during movement. An energy source for a bicycle is muscular force of the person. During movement of a bicycle there always appears a source of mechanical energy which the dynamo-car will transform to the electric energy. This source is more reliable than batteries or accumulators and it does not depend on forgetfulness of the bicyclist. (Without a doubt, this technical system has some lacks. We will dwell upon them and on ways of solving these problems in detail during consideration of other sections.)

### 2.2.1. Definition



“The law of “energy conductivity” of the system: A necessary condition for the life capability in principle of a technical system is the unhindered passage of energy through all parts of the system”.

Altshuller, G. S. (1984). *Creativity as an Exact Science: The Theory of the Solution of Inventive Problems* (A. Williams, Trans.): Gordon and Breach Science Publishers.), p. 225.

“The corollary of Law 2 is also significant: It is necessary to ensure conductivity of energy between this part and the controlling organs in order to control the part of the technical system.”

Altshuller, G. S. (1984). *Creativity as an Exact Science: The Theory of the Solution of Inventive Problems* (A. Williams, Trans.): Gordon and Breach Science Publishers.), p. 226-227.

The law refers to the section “Static”, to be more precise, to the laws which define the beginning of life of technical systems.

### 2.2.2. Theory

#### 2.2.2.1. Through pass of energy as an estimated parameter of the technical system

The first condition of viability of the technical system is described by the Law of completeness of parts of a system – presence and the minimum working capacity of the basic parts of system (Engine, Transmission, Tool and Control Unit).

Viability is considered to be the qualitative characteristic which includes a number of estimated parameters.

The ability of the technical system to perform the function, to be operated, to coexist, to cooperate, and also to compete with other technical systems depends on many evaluated parameters: (defined for each technical system) – speed, reliability, cost, range of use, etc..... In process of development of the concrete technical system the definition of „viability” extends. It is supplemented with the new evaluated parameters.

Thus, the additional criteria, evaluated parameters, are necessary in order to increase viability of the technical system in process of increase of requirements of people to parameters of the performed function, development of the technical system, toughening of a competitive environment. ... (The note: but in this case we speak about the estimated parameters for the model of the technical system.

Coming back to the illustrated example at the beginning of the chapter, we will draw conclusions on its basis. What meaning does the statement has: « for maintenance of the minimum working capacity of the technical system through pass of energy through all parts of the technical system» is necessary besides the presence of the basic parts of the technical system: Engine, Transmission, and Tool?

For the considered technical system of illumination “Engine” - batteries is alien from the point of view of passage and transformation of mechanical energy. (.....) Batteries, accumulators can be used as an additional “source” and “an engine” of this technical system.

The through pass of energy is produced of the energy source – muscular force of the person which come through the Engine, is transmitted to the Tool and further – to the Product (sense organs of the person, an eye).

#### 2.2.2.2. The typical mistakes

In order to understand and comprehend the essence of the law, it is necessary to read attentively some definitions, the theory, examples. Do not hurry. New ideas are hardly recognized not only in our society and in the world, but as well in our head.

The through pass of energy is important at first not for the technical system, but for the user of this technical system. Pay attention to the words in the definition – «the condition of basic life capability». To be more precise, the ability of the technical system is described here which is able to fulfil the function.

#### 2.2.2.3. Example 2. 1. Red thread. (Explanation of the theory)

Since 1776 following the order of Admiralty factory workers had started to intertwine ropes with a red thread making ropes for military fleet at the factories. The thread was intertwined so that it could not be removed even from a small piece of a rope. What aims do they pursue?

Two important problems were solved thereby. First, in process of use, ropes were used up and their further application became dangerous at the definite thickness. The red thread was intertwined so that at reduction of a thickness of a rope by certain size it was possible to signal about it. The second problem dealt with the larceny of ropes from factories for their personal use. There was a red thread in any piece of a rope and it was easy to expose the criminal.

This example serves as a good vision of the Law «Power conductivity». For maintenance of the minimum viability of the technical system energy should pass like «a red thread» through all parts of the technical system.



## 2.2.3. Model

### 2.2.3.1. The four- element scheme

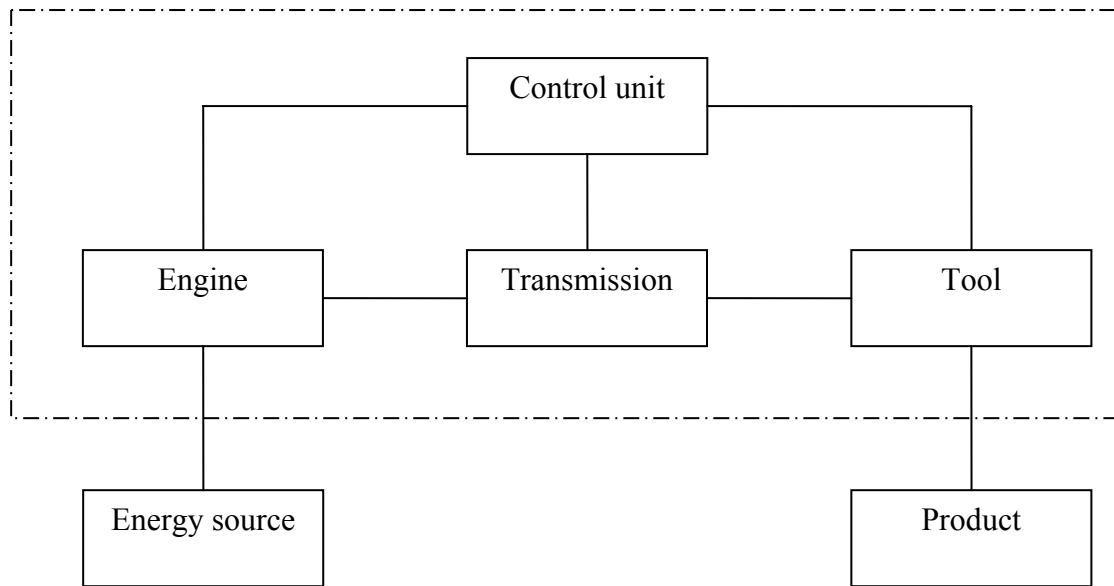

Fig. 2.1. The main parts of the technical system.

### 2.2.3.2. Example 2.2 (Sokolov's loudspeaker) – a thorough pass of energy

For the coil of the loudspeaker the copper wire, which has been reeled up in one layer, is usually used. But in the first years of development and mass application of loudspeakers magnets did not possess sufficient magnetic force for creation of necessary sound pressure on a loudspeaker exit. (The note: sound pressure depends on current strength in a conductor and forces of a magnetic field. A human ear perceives sound pressure as loudness of a sound; however, this dependence has the difficult character).

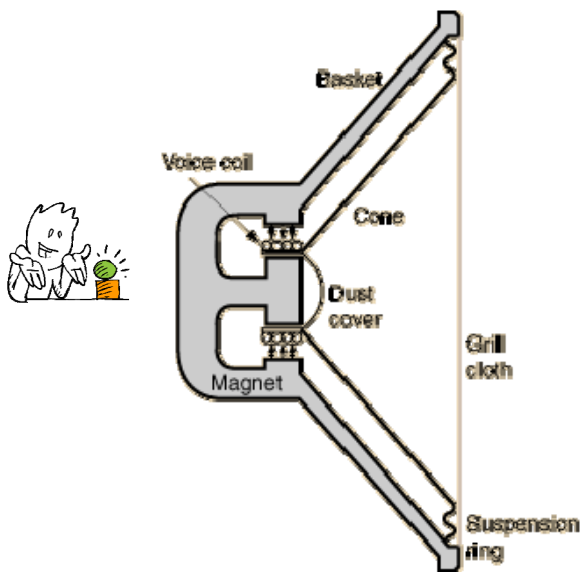

Figure 2.2. Cross section of a loudspeaker



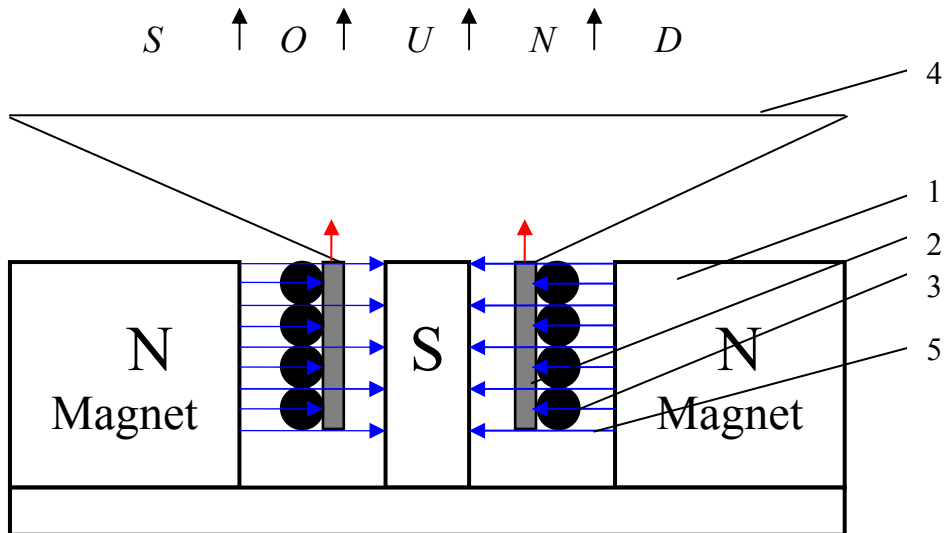

Figure 2.3. The cross section of a magnetic chain of a loudspeaker

The Figure includes:

- 1 – magnet
- 2 – coil assembly
- 3 – coil laps (waps)
- 4 – diffuser
- 5 – line of force of a magnetic field

There are only three obstacles for power lines of a magnetic field which are located between two poles of a magnet and which weaken a magnetic field. These obstacles are an air interval; a carcass of the isolated material for the coil; and a copper wire. The less air interval is and thinner a coil carcass is, the fewer losses will appear in a magnetic chain. And the magnetic field will be stronger. That means that sound pressure and loudness of a sound will be stronger.

A copper conductor causes losses in a magnetic field.

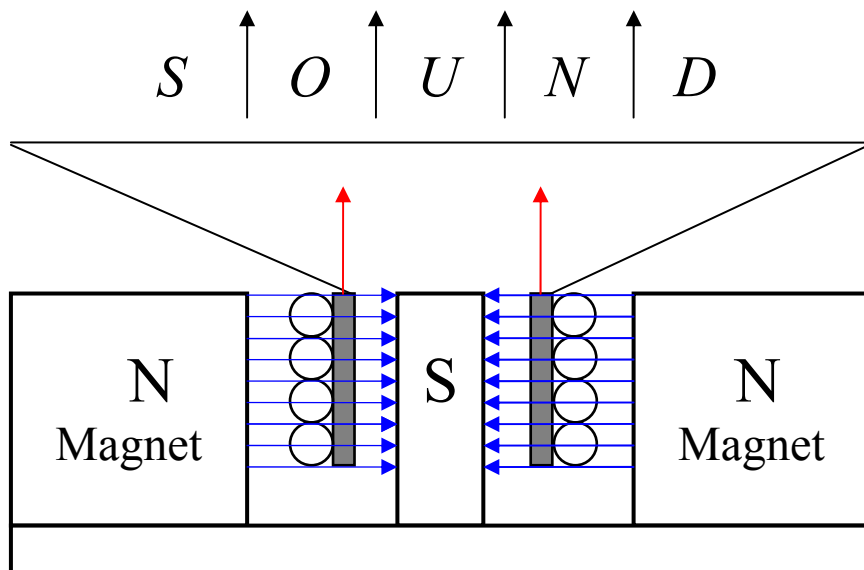

Figure 2.4. The cross section of a magnetic chain of a loudspeaker

The figure illustrates the changes: instead of a copper wire the wire from a ferromagnetic material, for example, the steel is used.

The inventor, the Sokolov, has patented a loudspeaker in 1936 in which the winding part is executed from a ferromagnetic material for the purpose of increasing its efficiency. The ferromagnetic material conducts well a magnetic field, without bringing losses in a magnetic chain.

### 2.2.3.3. Power conductivity of the four elements model

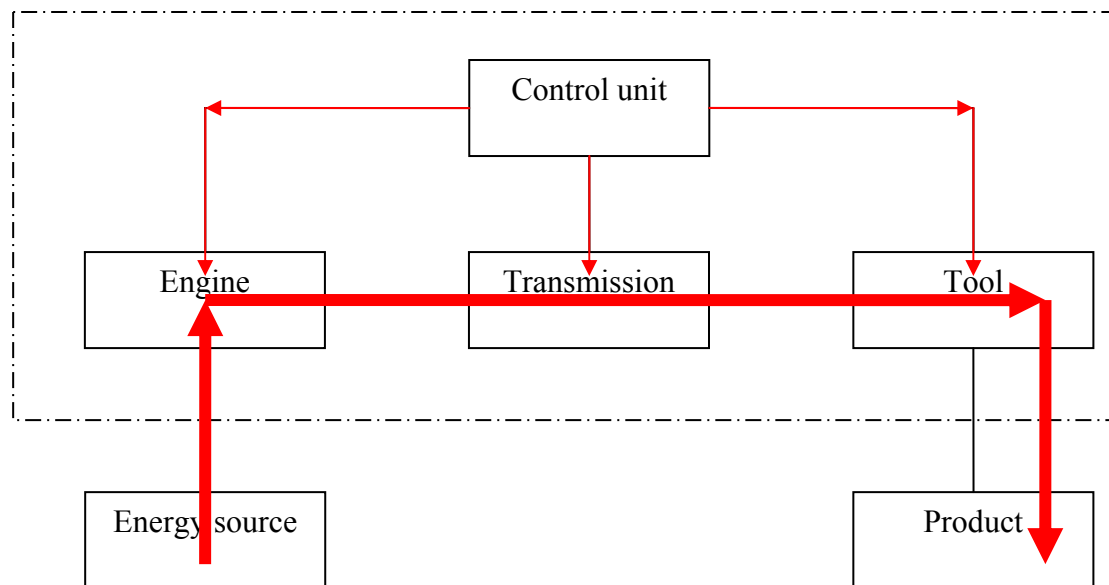

Figure. 2.5. Power conductivity of the four elements model

#### The consequence of controllability

« In order the part of a technical system was operated, it is necessary to provide power conductivity between this part and the control unit». What does it mean? How should we work with it?

1. It is necessary to construct four element model of the technical system.
2. To analyse whether there is a through pass of energy in parts the technical system.
3. To analyse whether there is energetic conductivity between parts of the technical system and a control unit.
4. To establish what fields are used for management and to analyse necessity and possibility of replacement of badly operated field by well operated in accordance with following order: gravitational – mechanical - thermal - magnetic - electric - electromagnetic.

#### The inverse problem – to break power conductivity

During the solution of some problems inverse action is required. It is necessary not to admit a through pass of energy in order to prevent harmful influence of the technical system on a product. In this case it is necessary to define at first the function.

## 2.2.3.4. Example 2.3. A safe switch of a press.

Press machines (a piece of equipment used to put weight on something in order to make it flat or to force liquid out of it) or mechanical hand-operated scissors are used at some factories. The worker delivers manually a half-finished material to a zone of processing, and then, turns on the press. Danger emerges because the hand of the worker can appear in a dangerous zone at the moment when the press is switched on. How to prevent the on-switch of the press in case of hand hit in a dangerous zone?



We will represent on the scheme of the technical system which harmful action should be prevented (fig 2.6).

It is necessary to improve controllability of a press: the press should not be switched on, when a hand emerges in a dangerous zone. Thus, the function of the new technical system will be «to switch a press on only in that case, if any of hands of the worker are not in a dangerous zone».

The operation of a press is completed in this case in such a way that if a hand of the worker appears in a dangerous zone it is not allowed switching the press on. To say it differently, the mechanism is uncontrollable in the described problem: the mechanism works in the case, when one, at least one hand is in a dangerous zone. On the scheme (fig 2.7), there are no power communications – red arrows – in an operative chain between the Control unit and other parts of a system. Uniqueness of this situation is explained by the fact that there are some dangerous moments, when the first worker delivers an intermediate product to a processing zone using one hand, and the second worker switches a press on. It is necessary to destroy, to break off a through pass of energy in any part of a chain in case, when a hand appears in a dangerous zone.

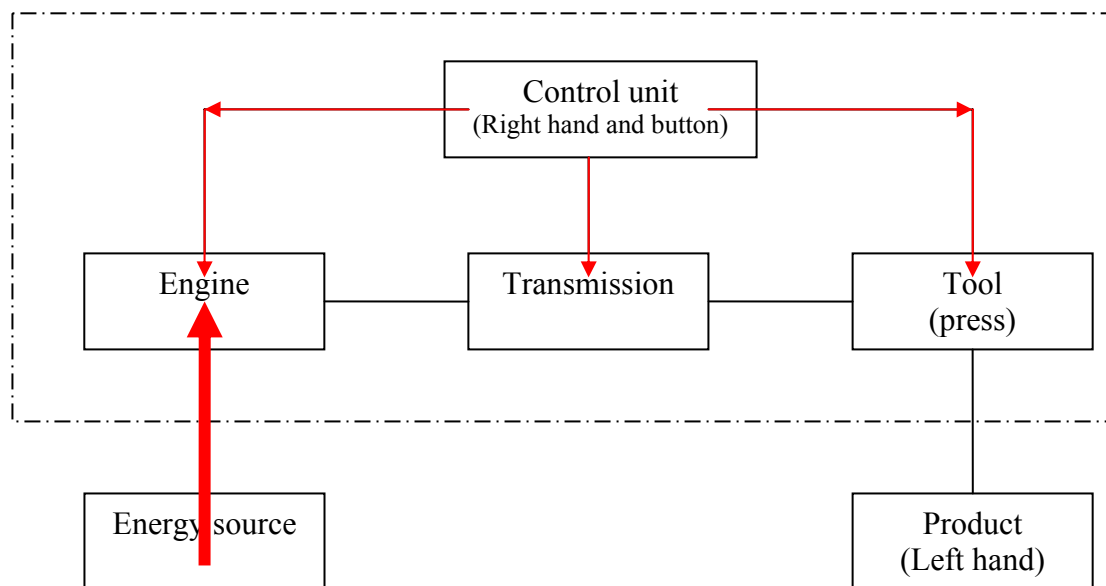

Figure 2.7

The changes are reflected in the following scheme according to the decision to operate a press by two hands. The control device switches a press on only when two buttons are pressed simultaneously by two hands. A through pass of energy through a system and further to a product is interrupted (in a case when a hand together with a processed product appears in a dangerous zone).

Energy source → → →Left hand → Engine → → Tool (press) →Product (+hand)

Energy source → Engine → Right hand → Left hand → →→Tool (press) → Product

### Example 2.4. (Protection against electronic scanning)

We will demonstrate one more example in order to illustrate that case, when it is necessary to break off power conductivity of a system.

The beautiful and attractive exterior of buildings and of windows of modern banks and of a casino influences very essentially their business.

But the electronic equipment is established in these establishments, which activity (various codes, passwords, etc.) can be easily scanned, read out using radiated radio signals. The premise should be impenetrable for electromagnetic waves in order to avoid these problems taking into account safety conditions. But to close all windows using metal boards is not beautiful for an exterior. What should be done?

It is often possible to see graceful curtains on windows in bank premises. They are made of metal chains. (The photo 2.8.; 2.9.) For what purpose are they used?



Fig. 2.8.

The photo illustrates the window of a known casino in Europe.

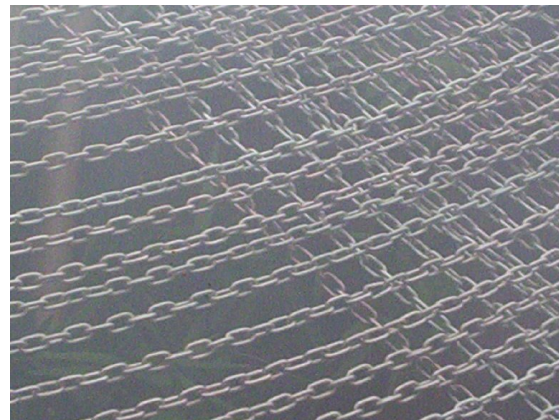

Fig. 2.9.

The photo illustrates the curtain structure (the image is increased)

### *The model of the "Harmful" machine*

The model «Harmful machine» is used in order to solve similar problems. The matter is that there is often an imposing on the useful effect (efficiency) of the harmful element while dealing with practical problems. A model of "the harmful machine » is created in order to define the parts of a system correctly, which causes this harmful influence, and leads to the selection of a changeable element.

The construction logic of the harmful machine is the same as of the ordinary technical system. We begin the analysis with the formulation of the harmful function which disturbs us. The "Harmful" Function is to accept and to write down signals from the electronic equipment which is located indoors.

Product: a signal.

Tool: a scanner-device

Transmission: airspace indoors and outdoors, a building, a window which is located between electrical equipment and a scanner.

Engine: Electrical equipment.

## **The useful, technical system.**

The Function. To make a good impression of a firm (of a casino, of a bank) with the own appearance.

The Product. An eye of a person.

The Tool. Electromagnetic waves of visible diapason.

The Transmission. The **internal volume of a building**, a window, curtains. And **the air environment which emerges from a window and reaches an eye of the observer.**

**The Engine.** Reflexion of sunlight or artificial light of internal walls and of surfaces of objects indoors.

The energy source. Sunlight or artificial illumination.

## **The harmful technical system.**

The Function. To read out the data of the electronic equipment located indoors.

The Product. Radiation of the electronic equipment.

The Tool. A scanner outside.

The Transmission. **Internal volume of a premise, of a wall**, a window, curtains. And **the air environment from a window to the scanner.**

The Engine. The electrical equipment.

The Source energy. An electrical network.

If two models of technical systems, useful and harmful , are represented graphically, it is easy to see that the general part of transmissions coincide in the useful and harmful systems.

### **2.2.4. Instruments (how to use)**

For what purposes can we apply the instruments? For:

- Solution of practical problems: creation of «the useful machine»;
- Solution of practical problems: destruction of «the harmful machine»;
- The analysis of the technical system in accordance with the Law – an estimation of competitive advantages of the technical system; estimation of weak places of the technical system;

an element constituent which forecasts development of the technical system: what part of the technical system or what parameters of the technical system cause the greatest difficulties during the operation?

How to use?

1. energetic conductivity– Examples: 2.2, 2.5, 2.6.
2. about control – Examples: 2.5, 2.6.
3. a brake of energetic connection – Examples: a press; curtains 2.4, 2.5.



## 2.2.5. Example (Problem-Solution)

### Example (The prognosis for car «control»)



Imagine that you live in 1901 and work for the known firm “Mercedes”. It is necessary for you to make the prognosis concerning the world demand of cars for 25 years. For the prognosis, it is necessary to define correctly factors which limit growth of consumption of a product.

What do you think, what was one of deterrents of increase in release and in sale of cars from the point of view of a level of development of the technical system “car”?

- Car Cost?
- Speed of the car?
- Economy of the engine?
- Level of pollution in exhaust gases?
- Complexity of driving?

Yes, driving was difficult and even dangerous. The first cars involved only sportsmen-fans. Many automobile owners hired drivers.

The driver had to train long in driving.

Imagine that to you are offered to go for a drive with the speed of 50 km/h in the unstable car without lateral walls, a windscreen, a screen wiper, with set of mechanisms, with weak brakes and unreliable tyres. The workplace of the driver has been equipped by so many handles and control levers that ability to use them quickly came not at once. There were along three brake levers: on a transmission shaft, on back wheels and on so-called «a drop-type sprag» — a peaked core which was lowered on a road during lifting movement while brakes on a bias did not keep the car (a prototype of a modern hand brake). The designer did not bother whether it is possible to reach the lever and whether it is convenient to use it. The lever was installed there where it was demanded by a design, thereby demanding from the driver to demonstrate improbable acrobatic abilities.

How to apply the law «Power conductivity of parts of a system» in order to improve driving skills?

According to the second consequence of this law «It is necessary to provide power conductivity between this part and control units in order to operate the part of the technical system ».

Absence of such communications made driving difficult and unreliable, demanded special and long preparation of drivers. To say it differently, they constrained development of the technical system and the quantity of produced cars. For firms-manufacturers it meant the missed profit...

It is important and useful to know the laws of development of technical systems not only for engineers, but also for researchers of the market. Their lack of knowledge or ignorance can lead to prognosis which may now cause a smile:

“Worldwide demand for cars will never exceed one million – primarily because of a limitation in the number of available chauffeurs”.

Market Research Study, Mercedes Benz, 1901.

Wehnert, Timon

European energy futures 2030 : technology and social visions from the European energy Delphi survey / Timon Wehnert .... - Berlin ; Heidelberg : Springer Berlin, 2007. (page 53).

Happily, managers and designers of the known firm have not listened to this prognosis, and have improved the car, have made it simpler in operation...

## Example (The management of the firm)

The operative problem of the fastest car will seem easy in comparison with a management problem of a small firm. The law «Power conductivity» is applicable in this case as well. Known advisers who are concerned with the management of firms (Josef O'Connor, Ian McDermott) give an example of an unsuccessful innovation in a firm in their book. One company has invited the expert (not authors of the book) to improve work of department of the administrative account. Thanks to the received recommendations the department began to work more effectively. However, for this purpose the department required much more information from other departments of the firm, for example, from the marketing department. The additional load concerning the data transfer has been laid down on the marketing department, distracting employees from the basic work. As a result of this innovation, the firm experienced difficulties with the basic production of normal manufacture and with sales of products for a long time...



As a result of the described approach, «power conductivity» of the firm structure has been broken; it became uncontrollable to a certain degree.

As a result of the accepted innovation, the department of the administrative account has affected «power conductivity» of the marketing department. And that means that it has affected «power conductivity» of the whole firm.

## 2.2.6. Self Assessment - (Questions, tasks)

### Summary.

We need a through pass through all parts of a system (the law of «Energy conductivity») in order the technical system functions to a minimal degree besides the presence of all parts of a technical system (the law of «Completeness of all parts of a system»).

It is necessary to provide energetic connection between this part and a control unit in order to control the part of the technical system.



### The basic definitions.

Energetic conductivity; a degree of a control; «harmful machine»; estimated parameters.

### Questions:

1. What parts are included in the four element model of a technical system?
2. What conditions of the minimum working capacity does a technical system have (in accordance with the law of Completeness of parts of a system)?
3. What conditions of the minimum working capacity does a technical system have (in accordance with the law of Power conductivity of parts of a system)?
4. Specify names of the parts which are included into the four element model of the technical system: Transmission, Product, Engine, Energy source, Tool, Control Unit.
5. (\*) Specify names of elements of the four element models of the technical system:  
Transmission, Energy source, Engine, Product, Tool, Su-Field, Environment,  
Control Unit.....
6. (\*) What lacks of the dynamo-car which has a transmission mechanism in a bicycle wheel?  
From your own point of view? (From the point of view of Laws of Engineering System of Evolution)

The traditional dynamo-car (the electric generator) is installed as a source of the electric power for devices of illumination of a bicycle. Energy of rotation is transferred to a dynamo-car by a wheel. For this purpose a dynamo-car has a ridge castor, which is placed on the shaft of a generator. During the contact with a rim of a wheel, the castor rotates and causes a rotation of a shaft and of a rotor of a generator (A photo made by the author).



Fig. 2.10.



Fig. 2.11.



Fig. 2.12.

The Photo illustrates the traditional dynamo-car (generator), installed on a bicycle.

### *The Exercises.*

1. Compose the four element model of the technical system for road illumination on a bicycle. The technical system consists of a headlight (with a bulb, glass and a reflector), supply lines (wires), a bicycle frame (serves as one of conductors), the switch; the generator of an electric current (dynamo-car); a rotating wheel.
2. (\*) What is the basic function of the car, in your opinion? What is «Tool», «Transmission», «Engine», «Energy source», «Control Unit» in a car according to the four element model?
3. The first bicycle. Some models of the first bicycles had no brakes and no handlebars as the devices for operation of a forward wheel and turning movement. Construct the four element model of a bicycle as means of transportation and mark power connectivity in it: a through pass of energy; presence of power connectivity between parts of the technical system and a control unit.

### *The Tasks.*



Fig. 2.2 and 2.3 illustrate the sectional view of a magnetic chain of a loudspeaker. For example, the strongest magnets are used in powerful concert loudspeakers. And for the further increase in capacity, it is desirable to lower losses in the magnetic chain, brought at the expense of the case of the coil. Besides, the heavy current proceeds through the coil in powerful loudspeakers, the coil heats up strongly and can fuse. In these conditions it is important to blow the coil by air from different directions in order to cool it. But the case of the coil, made from electrically insulated material, serves as a heat insulator, which prevent the coil from cooling. What do you suggest?

Prompt-1: Examine the technical system from the point of view of the performed law «energetic conductivity», as it was shown in the Example 2.3.

(Prompt-2: let us formulate the contradiction. «The case of the coil should be used in order \*\*\*; and the case of the coil should not be used in order \*\*\*»).

The speed record of the car. The first car with the rocket engine «Blue Flame» became the first



car which has overcome speed of 1000 km/hour. This car has reached the speed of 1001,452 km/hour on an equal surface of the extinct (dried up) salt lake of the State of Utah under control of pilot Gari Gabelich in 1970. One of the problems with which designers have faced: how to implement the braking of this car?

## 2.2.7 References

- Altshuller, G. S.** Creativity as an exact science. — M.: Soviet Radio, 1979. (Russian), Pages 124-125.
- Altshuller, G. S.** (1984). *Creativity as an Exact Science: The Theory of the Solution of Inventive Problems* (A. Williams, Trans.): Gordon and Breach Science Publishers.). Pages: 225-227.
- Salamatov J.**, System of development of creativity laws. /In book: «Chance of adventure»/ Copiler. A.B. Selutsky. – Petrozavodsk: Karelia. 1991. (Russian). – Pages 68-75.
- Wehnert, Timon.** European energy futures 2030: technology and social visions from the European energy Delphi survey / Timon Wehnert - Berlin; Heidelberg: Springer Berlin, 2007.
- Josef O'Connor, Ian McDermott.** The Art of Systems Thinking: Essential Skills for Creativity and Problem Solving. HarperCollins Publishers Ltd., 1997.



# tETRIS

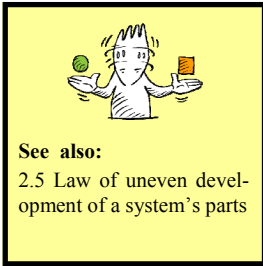

## 2.3: The law of harmony of the rhythms of parts of the system

I went upstairs using a wide spiral staircase while rising from a hall into office premises in one of the known European banks. This ladder has reminded me spiral staircases, which I saw in many medieval castles and fortresses... What similarity do they have?

The inhabitants of a fortress should protect each brick, each step of the ladder, each turn of a corridor. Those ladders, which should become an obstacle for the enemies rising from the bottom in the upward direction, are twirled in a direction from left to right, if to look at it upwards from the bottom. The matter is that a soldier, who walks upstairs, who battles with a sword in the right hand (and the percentage of such soldiers is 90 %) has to open the left side of a breast – the side, where his heart is located. A soldier, who protects a pass on a ladder and who stands above of the opponent, has a big chance to achieve a victory because the left side of his breast is covered by the right hand at the expense of a turning of a ladder.



### 2.3.1. Definition

An essential condition for the living viability in principle of a technical system is the harmonization of the rhythms (frequencies of vibration, periodicity) of all parts of the system. Altshuller, G. S. (1984). *Creativity as an Exact Science: The Theory of the Solution of Inventive Problems* (A. Williams, Trans.): Gordon and Breach Science Publishers.), p. 227.



### 2.3.2. Theory (Details)

Two conditions of basic viability of the technical system are described in the first and in the second laws:

1. Presence and the minimum working capacity of the basic parts of the technical system, (Engine, Transmission, Tool, Control Unit).
2. A through pass of energy in parts the technical system.

The third law introduces one more condition, one more evaluated parameter of the technical system the harmony of rhythms of parts of the technical system. One typical error during the analysis of a technical system in accordance with the Laws of development of technical systems is that a user begins the analysis without a proper formulation of the function which is required from the analyzed technical system.

Depending on a function, it is required to co-ordinate rhythms of parts of the technical system in one case and in others – disorganize.

The controlled parameters of the technical system can be: frequency, periodicity, a direction, speed, a phase, sequence, integration air space (porosity) and others.

In this example at the beginning of the chapter, the coordination of a direction of movement on a ladder and a direction of movement of hands during a battle is described for the defender of a fortress and a deviation of these parameters for the attacker.

To say it differently, the choice of the mismatch and of the coordination depends on this function, which fulfilment must be provided.

The inconsistency of rhythms of parts of the technical system is one of the reasons of non-

uniformity of development of the technical system (along with the external reasons: occurrence of new requirements of the person to the technical system; interaction with other technical systems, etc.). The detailed description of the Law «Non-uniformity of development of parts of system» is represented in chapter 5.

### 2.3.3. Model

For the analysis of the technical system concerning the coordination of rhythms of parts of the system, the four element model of the technical system is used. It is necessary to pay attention not only to the presence of the basic parts of the system and power connectivity between them during the analysis of these parameters, but mainly to the parameters of this connectivity – fluctuations, periodicity, etc.

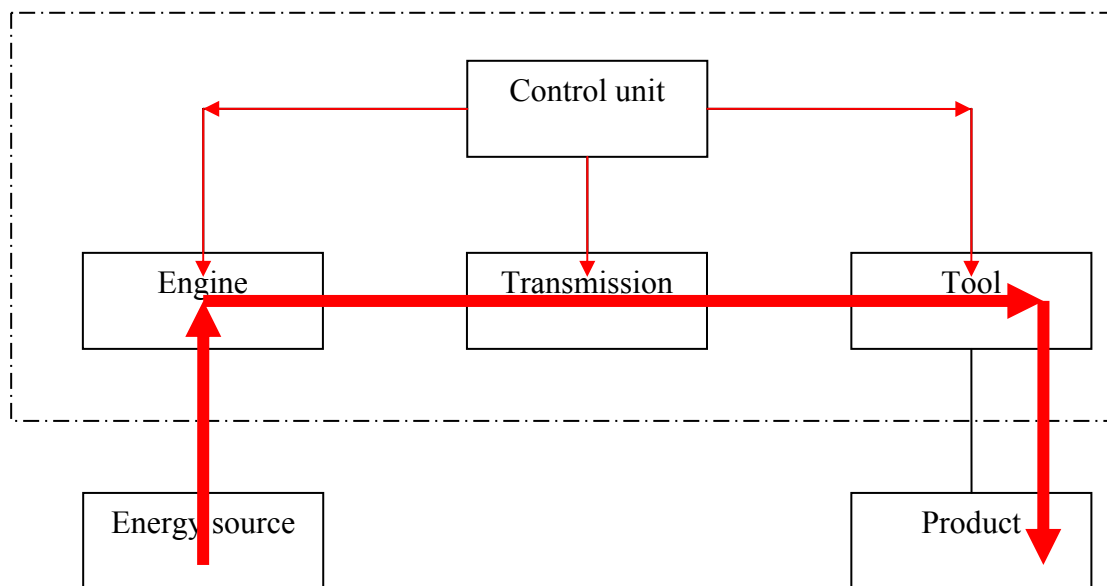

Fig. 3.1.

### 2.3.4. Instruments - Tools (how to use)

For what purposes to apply? For:

- solution of practical problems: problems of change;
- solution of practical problems: problems of measurement;
- the analysis of the technical system in accordance with the Law - an estimation of
- competitive advantages of the technical system; identification of weak parts of the technical system;
- a component for the development of the prognosis of the technical system: what part (parts)
- of the technical system are not co-ordinated with rhythmic?

How to apply?

- the analysis of the technical system on the presence of the basic parts of the technical system using the four element model, the definition- what parts of the system fulfil functions of the Energy source, the Engine, Transmission, the Control Unit.
- to analyse the technical system on presence of contradictions between parameters of various parts of the technical system.





- to use the model of «the harmful machine» for the analysis. It is necessary to pay attention, mainly, to the parameters of power connectivity.

For what purposes to apply? For:

- solution of practical tasks: a search for reasons of undesirable effects;
- solution of practical tasks: the removal of reasons of undesirable effects
- the analysis of a technical system in accordance with the Law – estimation of competitive advantages of a technical; the identification of weak parts in the technical system;
- development prognosis: one of the approaches is used to forecast the development of the technical system: the presence of the coordination and the mismatch of parts of the technical system

How to apply?

1. To search and to remove reasons of undesirable effects: the presence of the mismatch and the organisation of the coordinated conditions – Examples 3.1, 3.2, 3.3, 3.4, 3.5.
2. To search and to remove reasons of undesirable effects: the presence of the mismatch and the organisation of mismatched conditions – Examples: 2.3, 2.4, 3.3.

### 2.3.4.1. Example 3.1. Paralympic Games

The following problem appeared on the “Paralympic” Games, which was organized for invalids. There was the race on a long distance for people with the total absence of sight and hearing. Each sportsman of the “Paralympics” Games has an assistant, the sportsman-professional, in order to run in a correct direction. The assistant "leads" the partner – their hands are connected by a thin and easy ribbon. There was no problem concerning the false direction, each assistant "led" reliably the ward. But sportsmen ran uncertainly, without the feeling of the competitive atmosphere. How to transfer the atmosphere of the presence of fans, their emotions and support to sportsmen with absence of sight and hearing?!



The commentator of competitions has solved this problem within some seconds, having seen the uncertain run of sportsmen of the “Paralympics” Games. He has addressed the spectators with the request... (With what request – you will know after small theoretical explanation).

The traditional solutions:

- the sportsman-assistant should pull a string, designating applauds;
- to give the receiver with a vibrated ring to each sportsmen of the “Paralympic” Games, and
- to give the transmitter to the commentator ;
- not to hold such competitions...

Notes:

The “Paralympic” Games- the international sport competitions for invalids. They are held traditionally after the main Olympic Games, and since 1992 — in the same cities; this practice is fixed by the agreement between the International Olympic Committee and International Paralympic Committee in 2001. The summer Paralympic Games are held since 1960, and the winter Paralympic Games — since 1976. The name «Paralympic» is formed from the Greek prefix of « para » — «nearby, like everyone else»; parallelism and equality of Paralympic competitions with Olympic Games is meant.

Let us try to solve this problem. It is necessary to create the channel of « power conductivity» between spectators and sportsmen. We will begin with the definition of the function. **Function.** So, sportsmen should receive support from spectators. Any kind of energy should be used as

the carrier of this information. Thus, the technical system is necessary in order to transfer information from spectators to sportsmen with the total absence of sight and hearing.

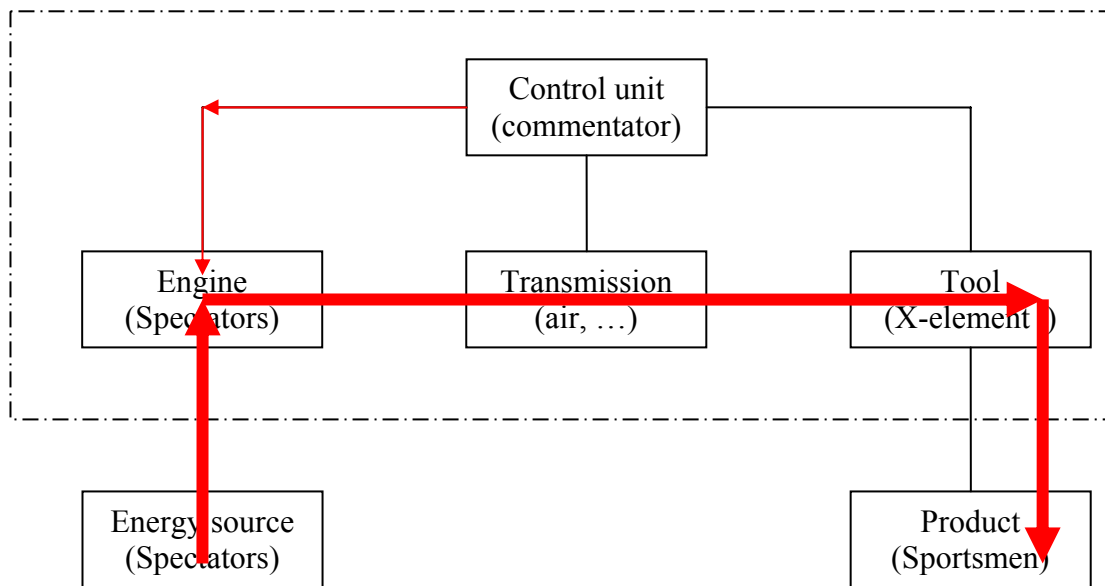

Fig. 3.2.

**The Product** in our case – the sportsman of Paralympic Games.

**The tool** – that directly surrounds the sportsman. In accordance with the conditions of competitions the sportsman-assistant should not help the partner, besides, to support him on the right track, on his path. Any technical means are inadmissible (various receivers, sensing devices, etc.). Other resources from an environment: air, a racetrack covering.

**Transmission** – a chain of objects that surrounds him from his body to spectators.

**The engine and the Energy source** – spectators.

A mechanical (acoustic) field and electromagnetic field of a visible diapason of waves (light) are accessible to sportsmen with hearing and sight. The tactile perception (a strong mechanical field) is only accessible to sportsmen without any hearing and sight. Exclamations of fans are not audible to sportsmen. It is necessary to strengthen the influence. Whether actions of spectators are co-ordinated? The sport commentator has asked spectators to applaud rhythmically and he himself has set this rhythm. The applauses of the spectators became rhythmical and co-ordinated. And the fluctuations of air strengthened by this resonance have achieved the object – sportsmen have felt a friendly greeting of spectators with their skin. (People without any sight and hearing have raised tactile sensitivity. On the one hand, it is the compensation of the organism mechanism, on the other side, – the ability strengthened by experience).

The note: compare the received solution with the traditional solutions represented above which are offered during the first minute's analysis of a problem.



Fig. 3.3. Loudspeaker

### 2.3.5. Example (Problem-Solution)

#### Example

In order to increase the general power of loudspeakers they are often united in pairs or in groups and are placed in the special general case. In this case, all loudspeakers in the group should be connected in phase. What does it mean? When a signal is supplied on windings of sound coils, diffusers of all loudspeakers should move tactfully in one direction, but not in opposite directions.



#### Example

In drawings, the fragment of history of development of a loudspeaker is presented. Actually, the head of a loudspeaker without registration badly reproduces low frequencies. The reason is acoustic short circuit. Sound pressure before a diffuser is not created, as the loudspeaker pumps over air from a forward wall of the diffuser to the backward wall, which moves already in an opposite direction by the time of the appearance of a wave from a forward wall. Thus, one

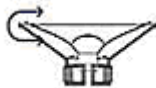
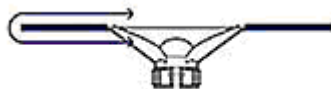

Fig. 3.4.

wave extinguishes another in accordance with the terms of four elements model. (The motion of a diffuser and air which is moved by the diffuser are not coordinated for the fulfilment of the function «to create air vibrations »)

A loudspeaker is installed in the sound shield in order to avoid the occurrence. It is a board which sizes are calculated in such a way that the shortest distance from a forward wall of a diffuser to the backward wall is equal to the half of the length of a wave in accordance with the calculated frequency. Thus, the coordination of rhythmic, fluctuations of parts of the technical system of «Loudspeaker» is achieved. (In this case, the motion of air masses caused by the direct and the backward motion of a diffuser does not suppress each other, but are folded in order to increase the power of vibrations. )

\* It is a question of transmission, its various parts in terms of four elements model.



\* consider the interaction of the «harmful» and the useful technical system

Fig. 3.5.

However, in this case, the following problem appears. The sizes of the sound shield do not allow applying this solution in household sound-reproducing equipment. The sizes of the screen should be 3x3 metre, in order not to admit the acoustic short circuit with frequency of 50 Hz. To be more precise, these sizes should correspond to the size of the length of a half-wave at this frequency. The screen should be big in order not to avoid the acoustic short circuit, and the screen should be not big in order the loudspeaker could be installed in household radio equipment. (In this case, the sizes of the acoustic screen do not match with the sizes of the body frame of household radio equipment – radio, tape-recorder, etc.) It is necessary to specify the parameters «the size of the acoustic screen» and «the size of the box» in order to solve the problem. The contradiction was resolved using the tree dimensional frame construction – the acoustic screen in the form of an open box. The equipment dimensions of vacuum lamps allowed using this decision. (Now it is possible to see the radio receivers of the last century in the sizes of 1x0,7x0,5 metre only in museums). However, with the advent of semi-conductor

devices – transistors and devices on their basis, the sizes of equipment have decreased in ten or more times.

Fig. 3.6.

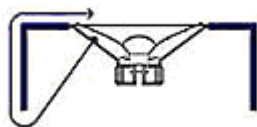

The box was made closed in order to prevent completely the acoustic short circuit in the small volume. However, there appears another problem. Low frequencies began to be reproduced badly, but it happened as a result of another reasons. If the air volume did not resist to the fluctuations of a diffuser dynamics in an open box, the closed box became similar to a spring. Resonant frequency of a dynamic has increased at the expense of elasticity of air volume in a box. (In this case, the vibrations of the air volume of the box do not match with the vibrations of the diffuser. To be more precise, the inner air volume of the box

and of the loudspeaker cone do not match in accordance with the parameter «elasticity».

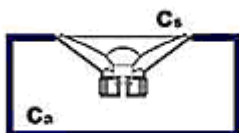

Fig. 3.7.

It was necessary to produce the boxes of the big sizes in order the elasticity of this air spring was much more below the elasticity of its own means of support of the dynamic. This solution allows us to specify the inner air volume of the box and of the diffuser in terms of the parameter «elasticity». Though, this solution leads to the mismatch of sizes of the loudspeaker box with sizes of a building. The direction Hi-Fi (High Fidelity – High fidelity of reproduction)

has generated the huge size of loudspeakers – speakers. The most complicated and the biggest stereo speaker in the world (the volume approximately 50000 litres) belongs to the American firm *Wilson Audio* and occupies the volume of a 20-metre room.

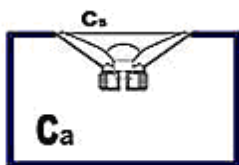

Fig. 3.8.

During the exemplified fragment of history of development of the acoustic design of loudspeakers the approaches to the solution of only one problem is illustrated – qualitative reproduction of low frequencies – basses. The coordination of rhythmic of parts of the technical system is the basic mechanism of the detected decisions.

How to resolve the contradiction « the volume of the loudspeaker should be big in order to decrease the resonant frequency of the dynamic; and the volume of the loudspeaker should be small in order to place it in premises». All this will be explained in the example of chapter 6 «Law of transition to a super-system (higher-level system)».

### Example



In the last century, in many countries, telephone calls of emergency services: firemen, police, medical aid – were carried out using different phone numbers. After understanding that such mismatch leads to time losses, it was offered to call emergency services using one telephone number.

The arrival time of emergency services was decreased. Though, in some cases, it is very important that all services arrive together. The work of all services should be coordinated and they should not disturb each other. Firemen who come earlier than medical men and police men are not able to give first aid to injured persons and can liquidate available proofs. Policy or medical men who come at first are not able to stop the spread of fire and reach the injured persons... It is very important to provide the coordination of arrival of all services.



The new solution appeared to this problem in South Korea. They wanted to coordinate emergency calls and arrivals of all three services to an accident. Thus, cars and the personnel of these services are located in one building, whence they can leave all together.

## Example

In many northern countries the traditional material for the building of cottages is logs. The logs were used for the building for centuries and this method is still used in Finland, Sweden, Russia and many other countries. Many old secrets of building have remained till now.



Fig. 3.9. The cottage made of logs  
(source: [www.lesoryb.ru](http://www.lesoryb.ru))



Fig. 3.10. The end wood blocks of logs  
(source Kon Corporation, <http://www.dom.kon.ru/>)

Logs in rotation round a longitudinal axis were put so that the side of a trunk turned during time of growth of a tree to the north, would appear outside of a building in the construction: annual rings of the North side are thinner, wood from this part is denser, possesses smaller structure and is steadier against influence of natural factors: the sun and moisture.

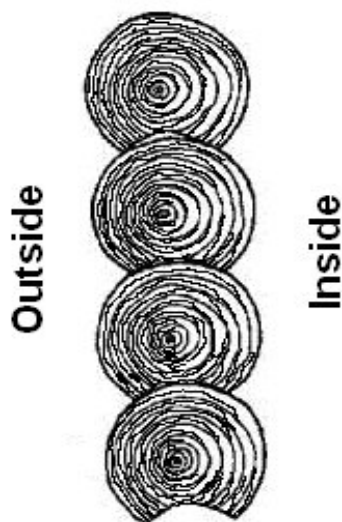

Fig. 3.11. Log's orientation



Fig. 3.12. The ends wood blocks  
(source: [www.lesoryb.ru](http://www.lesoryb.ru))

Thus, the log structure in the construction of a house has been made in accordance with natural factors for the purpose of improvement of quality of a structure.

## 2.3.6 Self Assessment - (Questions, tasks)

### Summary.

The coordination of rhythmic of parts of a system is necessary in order the technical system was technically viable, besides the presence of minimum efficient basic parts of the system and the through pass of energy in parts systems.

### The basic definitions.

Rhythmic, oscillation frequency, rate, coordination.

### Questions:

1. What parts are included in the four element model of a technical system?
2. What are the conditions of the minimum working capacity of a technical system (in accordance with the law of Completeness of parts of a system)?
3. What are the conditions of the minimum working capacity of a technical system (in accordance with the law of Power conductivity of parts of a system)?
4. What are the conditions of the minimum working capacity of a technical system (in accordance with the law of the Coordination of rhythmic of parts of a system)?



### Exercises.

Bumpers in cars are intended to damp the force of a blow at collision with an obstacle or with another car. Analyse, whether the parameters of a bumper are co-ordinated with values of the parameters of bumpers of another cars.



### Tasks.

1. Protection of medicines from children. It is known that children are very inquisitive and often try to open and to taste things they find. There are things which can not be given to children. For example, medicines must be reliably protected from opening by children, even if they take the medicines. Analyse the technical system of «a jar for medicines with an unscrewing cover» in terms of a through pass of energy. How to break this power link at an attempt to open a jar by children?



## 2.3.7 References

- Altshuller, G. S.** Creativity as an exact science. — M.: Soviet Radio, 1979. (Russian), Page 125.
- Altshuller, G. S.** (1984). *Creativity as an Exact Science: The Theory of the Solution of Inventive Problems* (A. Williams, Trans.): Gordon and Breach Science Publishers.). Page: 227.
- Salamatov J.**, System of development of creativity laws. /In book: «Chance of adventure»/ Copiler. A.B. Selutsky. – Petrozavodsk: Karelia. 1991. (Russian). – Pages 75-97.



## 2.4 The law of increasing of the degree of Ideality of the system

Public transport has appeared since more than 100 years ago and travel papers such as tickets appeared at the same time. It is possible only to assume how many tons of paper were spent for this short-living technical system...

The announcements, «a mobile phone-ticket, the travel ticket which a person can buy using a mobile phone» have appeared recently in a tram of the city Karlsruhe (Germany, Baden-Wurttemberg). Payment is made by a SMS-message on the phone of the transport company. The SMS-message is the travel ticket. There is any traditional ticket, but the function of the technical system «a travel ticket» is fulfilled. In this case, the function of the ticket is performed by the mobile phone and its facilities.

We have exemplified the extreme case, when the technical system does not only change its parameters to the higher levels, but also disappears, "is dissolved" in another technical system, transfers the function to it. The similar solution in the finance area is already known for a long time. These are "EC-cash". How works the law of increasing of the degree of Ideality of the systems, what are its peculiarities, its tools? We will explain all in this chapter.

### 2.4.1. Definition

The development of all systems proceeds in the direction of increasing the degree of Ideality. Altshuller, G. S. (1984). *Creativity as an Exact Science: The Theory of the Solution of Inventive Problems* (A. Williams, Trans.): Gordon and Breach Science Publishers.), p. 227-228.



### 2.4.2. Theory (Details) to the Law of Increase of Ideality

We use idealised descriptions of real subjects, processes and phenomena – with the help of models in the most different sciences. The minor, insignificant details are dropped in models for the given consideration in order to underline the main features. For example, we do not need the complete set of the constructional documentation of the Eiffel Tower in order to represent one of symbols of Paris. Sometimes, it is enough to draw a silhouette of the tower, made by several lines, or to represent a children's drawing.

The idealised concepts are used not only in models, but in various theories and sciences (physics, mathematics, geometry).

For example: «infinitely remote point», «the ideal thermal machine», «ideal gas», «infinitesimal sizes» and other concepts.

Let's consider a number of the key definitions used in TRIZ and which are connected by the concept of Ideality in detail.

#### The Basic definitions of Ideality

In our daily practice, we deal with the phenomena and processes for which organisation of work we should spare certain expenses: energy, time, money, etc. We need the reference point, which is unattainable in the reality, but can serve as the standard for the comparison in order to estimate the concrete technical system or the problem solution.

It is possible to explain the concept of Ideality with a fractional example: the maximum effect (E) at the minimum payment (C).

$$I = E/C$$

The more significant result we receive at the least expenses, the higher Ideality will be achieved. It is the general case. We will consider two special cases: 1. Increase of Ideality at

the fixed expenses by increase in the Effect and 2. Increase of Ideality on the fixed basis of the effect by the reduction of expenses.

When we have the fixed factors of the payment (economic, social, ecological and other aspects), the concept of Ideality reflects the achievement of the maximum possible result. For example, the achievement of the additional effect, which earlier was not expected. The cause of increase of Ideality is often the improvement of parameters in another area. Accordingly, during the solution of the technical problem, the economic, the ecological and the social indicators can be improved as well.

To receive the desirable result using the minimum factors of a payment. The ideal is the zero factors of the payment. (see «Ideal system»).

## **The Ideal system**

The system which performs the function without any expenses, i.e. using the zero factors of the payment (economic, social, ecological and other aspects).

## **The ideal solution**

The Ideal solution is not achievable basically, and is used as a reference point in order to estimate the obtained solutions.

The ideal solution is a solution which does not create any negative effects, no matter how wide we extend the limits of the System Operator (the Multi-screen scheme: the quantity of screens of the Scheme on all axes aspires to infinity).

## **The use of the Multi-screen scheme.**

Usually, during the assessment of the solution, we estimate the potential negative effects of this solution during the analysis of a concrete situation using the multi-screen scheme.

The multi-screen scheme which displays a concrete problematic situation, as a rule, has a limited quantity of screens. First, the quantity of screens is limited by our stereotypes (psychological inertia). Secondly, requirements, inquiries, needs of a concrete situation which contains many subjective factors.

The concept of **the ideal solution**, which was described above, is represented in order to increase the level of objectivity of an estimation of the received solution. Taking into account this definition of the ideal solution, we should avoid at the maximum capacity to use our stereotypes and to estimate the received solution from the different points of view arising at all categories of potentially interested persons in an unlimited historical interval of time.

## **The most desirable result (MDR) of the solution of a problematic situation**

The Most Desirable final Result (MDR) is the maximum explained aim or the system of the aims which we would like to receive as a result of the solution of a problematic situation. (MDR – Most Desirable Result).

According to the axiom of "Impossibility" of General Theory of Powerful Thinking while defining the Most Desirable end result (MDR) we consider that there is nothing impossible which can not be resolved. Though it seems to us that there are limits of possibilities and in this case, we should imagine that we have "a magic wand" which will help us to achieve the impossible results.

The Most Desirable final result (MDR) is an integration of all ideal systems which is necessary in a given problematic situation (see **Ideal system**) and Ideal Final Result (see **IFR**) with the aim of the maximum approach to the ideal solution.

It is necessary to distinguish MDR and the Ideal Solution. MDR is a solution which is represented to us as an ideal one within the limits of stereotypes of a concrete situation in the set interval of time in certain space, with certain resources, i.e. according to an axiom of "the Con-



crete situation» of the classical TRIZ-theory (see the axiom of «the Concrete situation»).

The Most Desirable end result (MDR) is an average concept which is found between Ideal Final Result (IFR) and the Ideal system, on the one side, and the Ideal Solution on the other side. The Ideal Final Result is formulated for one concrete contradiction which is included in the description of this concrete, problematic situation. The ideal system is a description of one of the systems involved in this concrete problematic situation. The Most Desirable end result (MDR) is an integration of our visualisations about the Ideal Final Result (IFR) and Ideal systems in the defined problematic situation. These visualisations are changed and specified in the course of the complex solution of a problematic situation

## The note

It is necessary to notice that at early stages of development of TRIZ there was practically no distinction between the Ideal system, the Ideal Final Result (IFR) and the Ideal solution. But in the course of TRIZ evolution, there appeared the necessity to divide these concepts. Therefore, in OTSM-TRIZ, the Ideal Final Result (IFR) and the Ideal system are bricks for the construction of an image of MDR. And the Ideal solution is used to estimate the obtained solutions. One more function of the Ideal solution is to serve as a tool which is used to overcome psychological inertia. When we have obtained the solution close to or coinciding with MDR, we should try to find parts of the multi-screen scheme where this solution creates or can create a negative effect. We should find these parts of the systematic operator (the Multi-screen scheme) which were not taken into consideration during the construction of an image of MDR. In other words, the model of the Ideal solution helps us to step out the limits designated by an initial problematic situation in the frameworks of which the image of MDR was defined and to look at a situation with eyes of the observers who are located outside of our consideration of the defined problematic situation, and who will react anyhow on our solution.

## The Ideal Final Result (IFR)

According to rules of ARIZ-85-C of IFR (the Ideal Final result) which is formulated as the concrete contradiction in which two incompatible requirements, which should be combined as a result of the contradictory solution, are accurately defined. IFR defines the aim and the criteria of an estimation of efficiency of the soluble contradiction. The closer our solution is to IFR, the better it is. Thus, the Ideal Final Result serves as a reference point in the course of work on a problem. That is why in the course of ARIZ- evolution, IFR was developed from one step into the system of steps which G.S.Altshuller named «the Package of IFR»: IFR-1; Strengthened IFR; IFR-2.

In OTSM technologies of « Contradiction » of the Package of IFR has been expanded by additional steps: IFR-2 is divided into the «Partial IFR-2» and the Folded IFR-2.

Each of partial IFR-2 matches the certain Strengthened IFR and also is defined after the corresponding formulations of the physical contradiction (in OTSM – the Contradiction of parameters) at the macro-level and at the micro-level. Thus, each Strengthened IFR matches at least two partial IFR-2: on the macro- and on the micro - level.

Each partial IFR-2 is an element of the mosaic, which draws the Folded IFR-2.

### 2.4.3. Model

The life of the technical system (as well as of other systems, for example, the biological system) can be illustrated with the image of dependency of the main parameters of the system on time. Such model of the technical system in the form of a S-curve (Fig. 5.3.) is widely used in OTSM-TRIZ. The S-curve shows clearly how the main parameters (speed, capacity, productivity, etc.) of the technical system are changed during its life. Each system has its own peculiari-

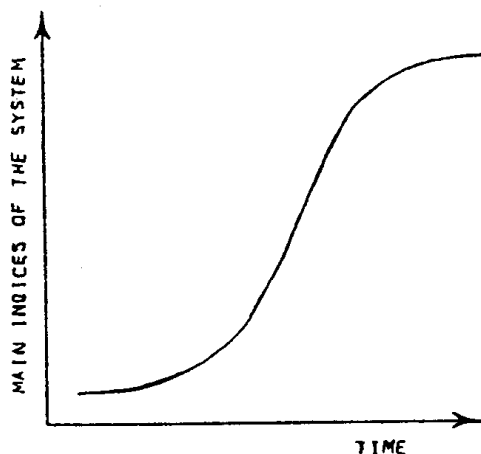

Fig.4.1 S-curve.

ties, its own «portrait» of the S-shaped curve. But there is something common in each «portrait», which is characteristic for all systems. 1 – «Childhood»; 2 – «Maturity»; 3 – «Old age» are such areas.

In the course of development of the technical system its main parameters are increased, the system becomes better, more ideal. It is necessary to construct the scheme of change in time of one of the main indicators of the system, using the patent fund and other sources about the previous development of the analyzed system. Further, using the received S-shaped curve to draw conclusions about that stage of development on which the technical system is found.

There are several stages, steps of increase of Ideality:

- improvement of parameters of a system (1-2 main) at the increase of costs;
- improvement of parameters of a system (1-2 main) at the unchanged costs;
- improvement of parameters of a system (the appearance of new functions) at the increase of costs;
- improvement of parameters of a system (the appearance of new functions) at the unchanged costs;
- improvement of parameters of a system at the decrease of costs;
- improvement of parameters of a system (the appearance of new functions) at the decrease of costs;

The significant decrease of expenses which are used to support the existence of the system and the appearance of new functions, and which extend significantly the application of the system takes place by the complete disappearance (by the rollback) of the technical system, for example, by its connection with another system or its transition to the sub-system with the transfer of its main functions to the new system.

#### 2.4.4. Instruments - Tools (how to use)



The stages of increase of Ideality	The methods of achievement
improvement of parameters of a system at the increase of costs	The intense usage of resources; engineered methods of the constructional design.
improvement of the main parameters of a system at the unchanged costs	The resource-saving technologies; optimal solutions; standard resource-saving solutions.
the appearance of new functions at the increase of costs;	The engineered methods of the constructional design; Value Analysis (at the insignificant increase of expenses)
the appearance of new functions at the unchanged costs;	The engineered methods of the constructional design; Value Analysis
improvement of parameters of a system at the decrease of costs;	Value Analysis, OTSM-TRIZ
the appearance of new functions at the decrease of costs;	Value Analysis, OTSM-TRIZ
The significant decrease of costs which are used to support the existence of the system and the appearance of new functions of the system.	Value Analysis, OTSM-TRIZ;

*Tools used to achieve the correct solution: Instrumental laws – the law of the completeness of parts of the system; the law of “energy conductivity”; the law of harmonizing the rhythms of parts of the system.*

## 2.4.5. Examples

### Example

Sailors used stars in the sky as the directional orientation for a long time. Any of sailors has reached a star. However, think how many ships have found the harbour, without going astray and how many human lives have been rescued thanks to this directional orientation.

The ideal is not achievable, but only with the orientation towards it; we can move ahead in the right direction.



### Example

The raft for transportation of logs is the ideal system. (We will notice that for real systems and solutions we can speak only about Ideality in the comparative degree because the ideal solution is by definition unachievable). Thus, it is possible to assert that a raft made of cargo – transported logs, is the more ideal solution, than the transport vessel transporting the cargo of logs. But the world is weaved from contradictions. And we can notice that transported logs on a vessel remain dry in comparison with the raft logs. Hence, other parameter – safety of a cargo has the smaller value. There appears a new problem...



### Example

Each kilogramme of the cargo is highly prized in a spaceship put into the Earths orbit. It is not an exaggeration. Really, in order to launch a kilogramme of the cargo into the orbit the Earth, it is necessary to spend means, which are comparable with the cost of one kilogramme of gold. At the end of the 20<sup>th</sup> century it was offered to make separate elements of interior decoration of a cabin of a spaceship of the pressed foodstuff. In emergency, when there will be any foodstuff it is possible to use parts of an armchair or an internal wall of the ship as food.



### Example

It is necessary to have enough fuel supply at distant space flights. How to provide the ship movement without any fuel? The spaceship trajectory is calculated in such a way that it is possible to use the gravitational pull of various planets. Fuel is not present, but the function «to Move a spaceship from one point of space to another» is performed.



## Example

Bellow, the fourth figure illustrates the cut (cross section) of a magnetic chain of a loudspeaker.

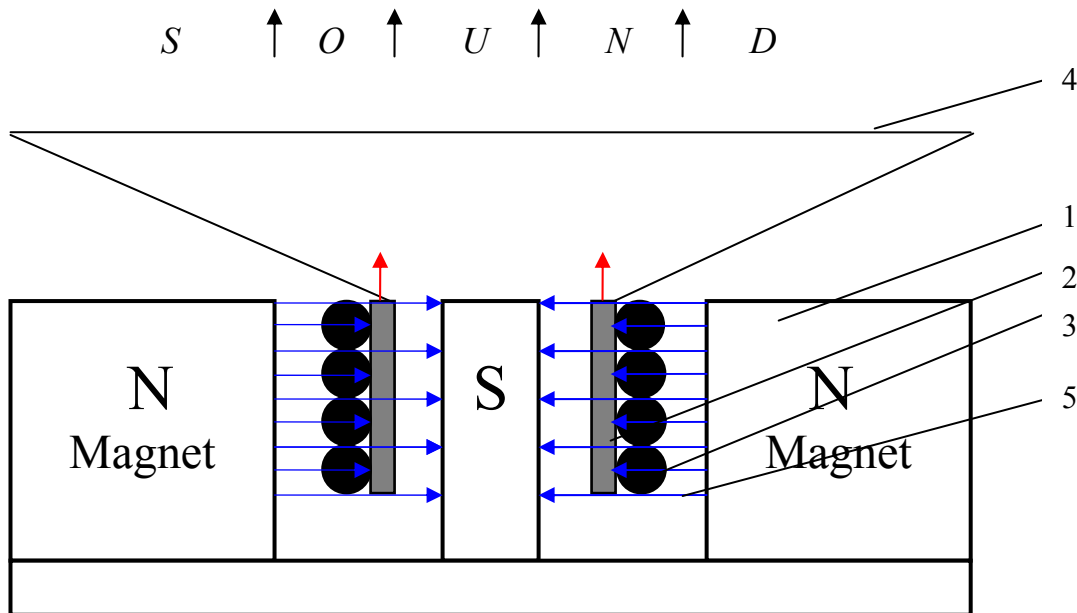

The figure includes:

- 1 – Magnet
- 2 – Coil assembly
- 3 – Coil laps
- 4 – Diffuser
- 5 – Lines of source of a magnetic field

The coil with a conductor, which is located in a magnetic field, are "Engine", the converter of energy of electric and magnetic fields in mechanical fluctuations of a diffuser and then of air. Earlier (chapter 2, an example 2.2, the task at the end of the paragraph), we already discussed a magnetic chain of a loudspeaker.

Usually the coil of a loudspeaker is reeled up on the special cardboard or plastic case and is installed between magnets. What is the function of the case of the coil? The case of the coil keeps the coils of the conductor in the centre of a magnetic chain of a loudspeaker, between poles of magnets. According to the earlier exemplified rules (see Chapter 1 "The law of the completeness of parts of the system" à "How to determine function of the technical system correctly") we will specify the formulation: «to compensate the action of elastic forces of laps of the coil and forces of gravitation on change of the location of the coil».

However, the case of a coil leads to undesirable effects. First, it brings losses of a magnetic stream. It occupies the small, defined place in an opening between magnets. And the more the distance between magnets is, the weaker a magnetic stream will be, and therefore, the capacity of a loudspeaker will be weaker as well.

Secondly, the most undesirable effect is worse of cooling of a conductor of the coil. In powerful loudspeakers, the big current proceeds through the coil, it is heated up strongly and can be fused. In these conditions it is important to blow a coil with air from different directions in order to cool it. But the case of the coil made from electrically insulating material serves as a heat insulator, which prevents from cooling a conductor of the coil.



What is the ideal case of the coil? This is the case which fulfils the specified function, but does not take a place. The expenses for its manufacturing aspire to zero. To say it differently, the case which is not present, but the function is performed.

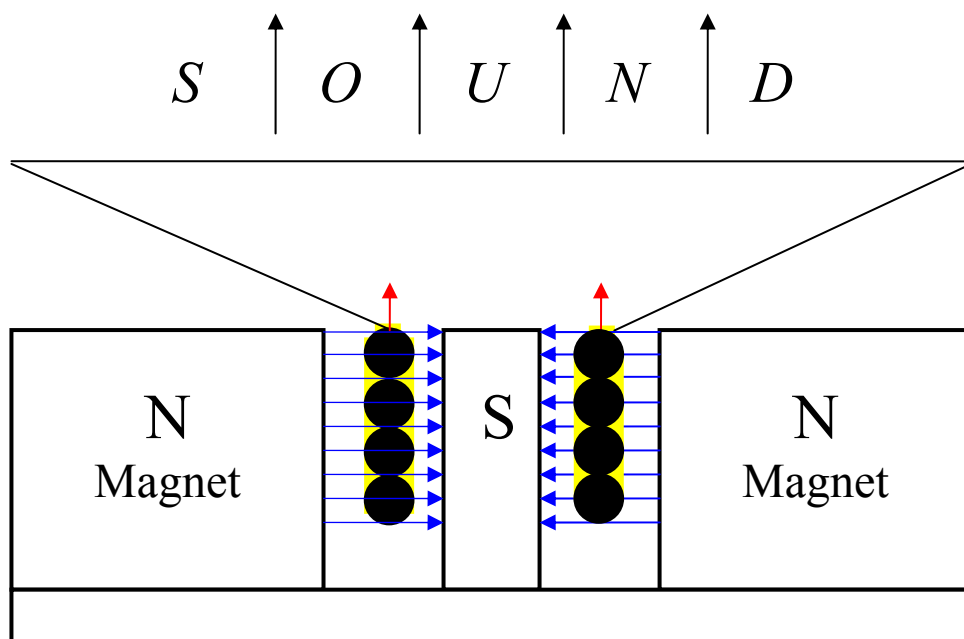

The coils without frames were created in which laps are fixed by special glue-compound. It is necessary to notice that in the old system the prototype of the compound existed already – laps of a coil were covered with lacquer in order to achieve the high resistance and the protection of a surface against the mechanical damages. But its resistance was insufficient to fix laps of a coil in the defined condition without the case of a coil. Besides, the problem of the positive and negative effects, which are made by the case of the coil, has not been discussed and described and as a consequence of it, it was solved only some time ago.

### Example

The dynamo-machine on a bicycle is usually installed in the form of the separate device. Mechanical energy of rotation of a wheel is transferred to a dynamo-machine by the contact of a castor of a dynamo-machine with a surface of a wheel of a bicycle. For the achievement of higher parameters of a system of illumination of a bicycle (brightness of illumination and thus, the capacity of a bulb, electric capacity) a more powerful dynamo-machine is necessary. The mechanical contact of a surface of a wheel and a castor of the dynamo-machine is based on a friction and it transfers its force with great effort to a more powerful dynamo-machine. The development of the system of illumination and the bicycle alarm system was constrained by the construction of a dynamo-machine based on the transfer of mechanical energy by means of friction during the direct contact of a dynamo-machine with a surface of a wheel.

In latest models of bicycles there were the dynamo-machines which have been installed in an axis of a back wheel. The axis of a wheel with the magnets which are located on it serves simultaneously as a rotor of a dynamo-machine. Transmission – a castor of a dynamo-machine and a surface of a wheel of a bicycle has disappeared because it was superfluous. The friction losses by the transfer of mechanical energy have disappeared after this. In such cases, we say that the system became more ideal.



## 2.4.6 Self Assessment - (Questions, tasks)

### Summary.

The peculiarities of existence of technical systems at a stage of their development (at the second and the third stage of an S-curve) are described by the following law.

Development of all systems goes in a direction of increase in Ideality. It includes many various mechanisms and consists of several stages. At first, it includes the increase in the key parameters, then, the decrease in a payment for performance of a function and the appearance of new functions. And a final stage – the connection with another system and the transfer of the function to this system or the performance of functions of another system.

### The Basic definitions.

Ideality; Ideal system; Ideal solution; MDR – Most Desirable Result; Ideal Final Result (IFR).

### Questions:

1. How we define the concept of Ideality?
2. How we define the concept of the Ideal System?
3. What solution is an Ideal one?
4. What is the difference between the Most Desirable Result and the Ideal Final Result solution?

How we define the concept of the Ideal Final Result?



## 2.4.7 References

**Altshuller, G. S.** Creativity as an exact science. — M.: Soviet Radio, 1979. (Russian), Page 126.

**Altshuller, G. S.** (1984). *Creativity as an Exact Science: The Theory of the Solution of Inventive Problems* (A. Williams, Trans.): Gordon and Breach Science Publishers.). Pages: 227-228.

**Salamatov J.**, System of development of creativity laws. /In book: «Chance of adventure»/ Copiler. A.B. Selutsky. – Petrozavodsk: Karelia. 1991. (Russian). – Pages 138-168.

**Khomenko N.**, “The law of the completeness of parts of the system” with OTCM-TRIZ interpretation. Karlsruhe, 2008. (Russian, manuscript, 09.07.2008)

**Khomenko N.**, “The law of increasing of the degree of Ideality of the system” with OTCM-TRIZ interpretation. Karlsruhe, 2008. (Russian, manuscript, 18.07.2008)



## 2.5 Law of uneven development of a system's parts

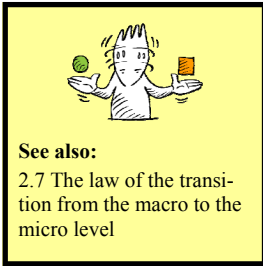

I am writing these lines in a new high-speed train TGV, crossing back and forth Europe at a speed of 350 km/hour. The speed is amazing, but with a high degree of probability it is possible to state that it lies next to the limit of a wheel-rail type of transport.

What was the most difficult problem while constructing such train? More powerful engines, the construction of a new railway track, a more advanced braking system? Yes, partly these challenges too. However, according to developers, the most challenging was ...a current collector.

In a TGV train the current collector bears a strong outward resemblance to the construction of current collectors in common trains. In the given paper we do not tell you about technological solutions applied in a TGV train.

We point out the most important issues in this example. During the life of any technical system (TS) its parts undergo an uneven development. Firstly, in every time period TS parts have a different level of development. Secondly, changes in the parts of a system take place not evenly, but in the form of an avalanche. There is always a part that holds back TS from its further advancing and increasing of its main parameters. It is this part («bottle neck») that gives rise to sharp contradictions. Thus, it is of great significance to determine this part.



Fig. 5.1 New high speed train TGV

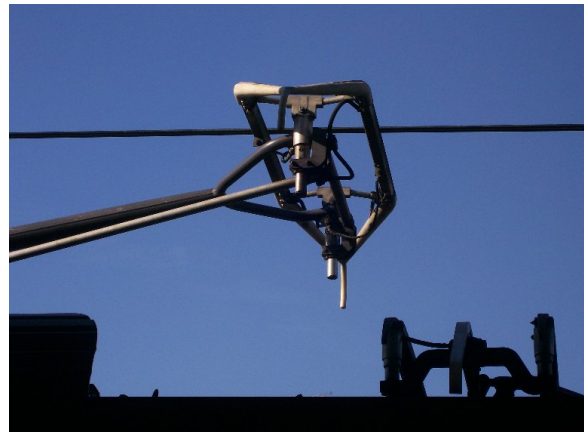

Fig. 5.2. Current collector of a train TGV

In the history of train development there were various factors that acted as restraining force in achieving necessary parameters (speed, length and weight of a train set, braking distance ...). The power of a steam engine gradually grew until it came into conflict with the quality of a rail track. Some years later technological achievements in the field of metallurgy have allowed creating more durable, lengthy and rather inexpensive rails for mass production. As a result, the technology of railing was responsible for a quality of a track and of a multi-branch network. Trains became quicker, transported more cargoes and connected remote towns. But the engine was not able to provide necessary power to reach the speed that a new track could allow.

The last «breakthrough» for a steam engine was the transition to a more power-producing, valuable fuel: petroleum products were used instead of coal. Surely, the engine was changed too – a higher steam pressure was necessary in order to produce more power. For that purpose,

a more durable (and heavier!) engine was required. The further increase of the main train parameters became possible with the transition to a new type of engine, i.e. an electrical engine.



Thus, while solving practical tasks and forecasting technological development it is very important to define correctly «a bottleneck» in parts of a TS. Furthermore, it is necessary to identify existing contradictions and direct efforts towards the continuous improvement of exactly this part.

## 2.5.1. Definition



The development of a system's parts proceeds unevenly; the more complicated the system, the more uneven the development of its parts is.

Altshuller, G. S. (1984). *Creativity as an Exact Science: The Theory of the Solution of Inventive Problems* (A. Williams, Trans.): Gordon and Breach Science Publishers.), p. 229.

## 2.5.2. Theory (Details)

The law belongs to the group «Kinematics», i.e. for advanced TSs that are on the second and third stages of developments. (See S-shaped curve).

We know that on the birth stage of a new TS, the technical system must contain minimally working main parts for a minimal working capacity. Besides, there must be power conductivity between TS parts as well as between the control body and TS parts. A rhythmic of TS parts must be coordinated in order to further develop a TS and to improve its parameters. It concerns primarily recreated technical systems which are on the first development stage (see S-shaped curve).

With development, the parts of TS undergo modification according to the changing demands of man and environment. TS includes component parts of a different development level on various stages of its life. These inconsistencies can be described with the help of contradictions. Especially, sharp contradictions arise in the «weakest» part of a system, in a «bottle neck».

One of the reasons for the inequality of system parts development is restricted resources. In the first place it is material resources as well as time for development, implementation and entrance to the market. Besides, substantial restrictions at this stage are usually introduced by available resources of methods of task solutions.

### Typical mistake:

Very often the improvement of TS begins with... an easily changing part of a system. Especially, it is typical for complicated tasks on overcoming problems in the weakest part. One of the reasons for this phenomenon is restricted possibilities of traditional methods of problem solution.

The falsity of this approach is very brightly underlined in the following joke.

A walking gentleman is looking for something on the pavement under a street lamp. The following dialogue takes place between a policeman and the gentleman.

- Sir, can I help you?
- Yes, I've lost my keys from my flat.
- Do you remember the place where you have lost them?
- Certainly, over there, near to my car... (shows at the car standing nearby)
- And why are you searching for them here, under a street lamp?
- It is lighter here!

We are laughing at this gentleman, but often act in the same way while improving technical systems...

And only after we completely exhausted all development resources of other parts of a system, we come back to our «bottle neck».

If we continue the illustration of the example with development of a TS «train», we will point out the following. To advance a TS, it is important to correctly formulate a function. That also means to define the variation limits of a TS. In case with a train TGV the limits were established in such a way that changes did not concern with the principle «wheel-rail». But exactly the part «wheel-rail» of the system «train» is a «bottleneck».

## Remark:

The next development stage of the train is a train on the electromagnetic plate. In the construction of such train the transition from the pair „wheel-rail” (macro level) to the electromagnetic interaction (micro level) is made. A current collector underwent some changes too – there is no sliding contact „current collector-conductor” any more. The function of energy transmission is performed by means of electromagnetic field.

(More detailed information about the next development stage of the train and the development law of technical systems that forms the basis of that stage can be found in 7 Chapter, Example 7.5).

## 2.5.3. Model

### S-shaped curve

The life of a technical system (like the life of other systems, e.g., biological systems) can be described in the form of dependency of a system’s main parameters on time. Such model of TS development in the form of a S-shaped curve (Fig. 5.3.) is widely used in OTSM-TRIZ. The curve demonstrates how TS and its main parameters change during its life (speed, power, efficiency and so on). Every system has its peculiarities, its own «portrait» of a S-shaped curve. But every «portrait» has something common, typical for all systems. Such segments are 1 – «Childhood»; 2 – «Maturity»; 3 – «Old age».

It should be pointed out that the development of the whole TS occurs unevenly due to the unequal development of its parts.

In the «Childhood» (Segment 1) a technical system develops slowly. As a rule, this development stage coincides with the stage of «Maturity» or «Old age» of its system-predecessor (Fig. 5.4.). A new system is weak yet; its main parameters can be worse than the parameters of the old system. There is lack of resources for the development of a young system. But a new operating principle has a significant potential.

The existence of an old system holds back the appearance of young „competitors“. And only after an old system is gone, a rapid development of a new system begins (the bending point **a**). The stage «Maturity» comes in (Segment 2).

From some moment (the bending point **b**) the development rates decline and the stage «Old age» begins (Segment 3). A new, young TS is ready to come. After the point **g** a technical system is changed by a new one or maintains the reached indicators for a long time (e.g. a bicycle).

## Lines of system evolution

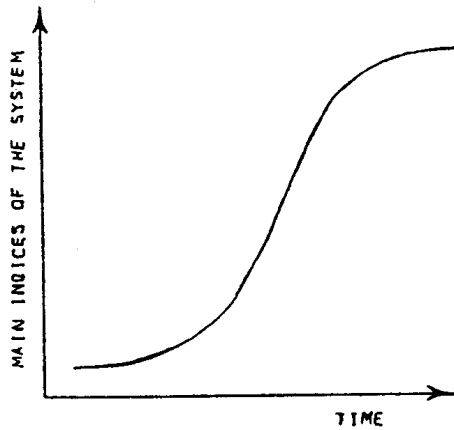

Fig. 5.3. S-curve. (See: Altshuller, G. S. (1984). *Creativity as an Exact Science: The Theory of the Solution of Inventive Problems* (A. Williams, Trans.): Gordon and Breach Science Publishers.) Pages: 205-216)

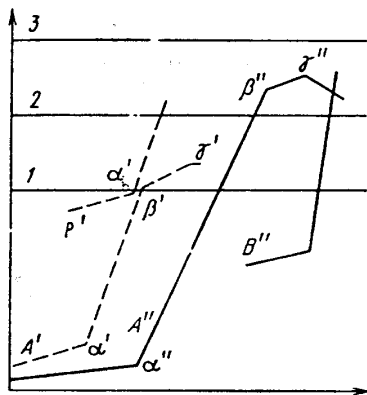

Fig. 5.4. (See: Altshuller G.S. (1979). *Creativity as an Exact Science*. Sovetskoe radio, Moscow. pages: 113-119).

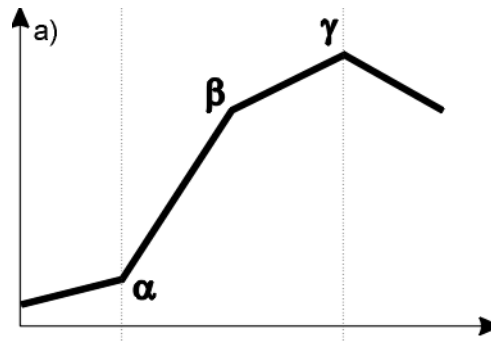

Fig. 5.5. Performance – Utilization

In the course of its development TS is the subject of constant changes. Materials are changed, some parts are replaced by others, more advanced parts. The life line of a specific technical system can be presented in the form of a number of S-shaped curves that constitute TS (Modis, 1994).

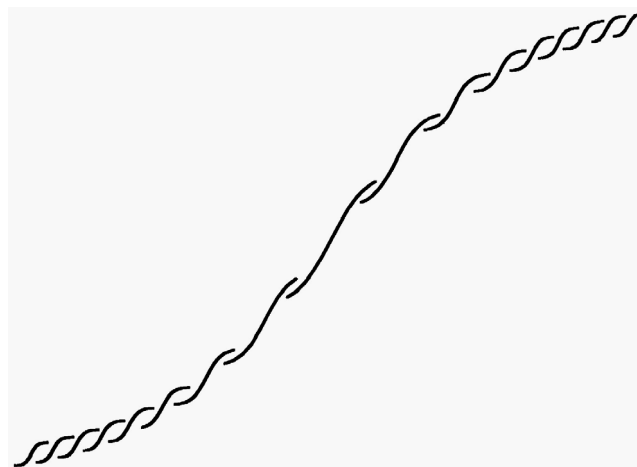

Fig. 5.6. S-curve, consisting of other S-curves representing subsystems. The horizontal axis represents time.

The development of TS occurs unevenly in many aspects. Several of them are pointed out below:

- TS have different development rates at various stages of its life;
- subsystems that are parts of TS have a different development level in any randomly chosen moment of life time of TS;
- subsystems have different time of life;
- development rates of TS even during one stage of its life are not even;
- a temporal revival of old subsystems is possible, which were excluded before under new conditions;

## 2.5.4. Instruments - Tools (how to use)

### 2.5.4.1. Development laws and their tools

It is necessary

to build a model of TS consisting of 4 elements. (see Chapter 1).

to analyze TS for power conducting capacity (see Chapter 2) as well as for matching (or mismatching – in dependence on the function required by us) rhythmic of a system (see Chapter 3).

to compare the whole system and every part of it with the perfect system (see Chapter 4).

During the preliminary analysis contradictions characterizing various parts of TS will be identified. It is necessary to evaluate what contradiction is the most limiting one. For example, in terms of a number of undesirable effects and of contradictions (in the context of the performance of the function chosen by us).



### 2.5.4.2. S-shaped curve

While solving practical tasks and forecasting the development of technical systems it is crucial to build correctly the «portrait» of the analyzed TS. It is important to know the development reserves of the given TS. It is necessary to build a chart of changes in time of one of the main system's indicators using a patent file and other sources about the previous development of a system which is to be analyzed. Furthermore, conclusions about the development stage in which TS is currently situated are to be drawn using the gained S-shaped curve.

### 2.5.4.3. Building of a network of problems and analysis of its structure

During the description of the current state of things in regard to TS to be analyzed, a network of problems is to be built (see Section ...). The network of problems includes problems and their partial solutions as well as their interconnections. The structure of a network of problems gives information about the uneven development both of the whole system and of the "bottlenecks".

## 2.5.5. Example

### Example

Listening to music was common at all times... In the middle of the last century sound-reproducing equipment saw a further development. Especially, electronic amplifiers were actively developed. In our opinion, the reason for this phenomenon lay in wide possibilities of resources, i.e. electronic base. During several decades of the last century the world witnessed two generations of electronic bases. Electronic lamps were replaced by transistors; transistors were followed by integrated microcircuits. This and other modern technologies allowed improving the sound quality, increasing mass production and making prices more moderate.

Loud-speakers were progressing not so actively. Their main parameters came into contradictions with man's needs to have a more qualitative sound-reproduction, on the one hand and with the possibilities of electronic base, on the other hand. Sound carriers (recording tape, radio



signal, vinyl gramophone records, etc.) as well as electronic amplifiers made it possible to increase the sound quality. Loud-speakers were exactly the «bottleneck» holding back the overall development of the sound-reproducing equipment.

Back to the middle of the last century amplifiers for sound reproduction which had nonlinear distortions of less than 0, 5% at the power of 50 W were produced. It is very good parameter. But a loud-speaker connected to such an amplifier enhanced distortions by 10-20 times! However, amplifiers kept on progressing thanks to the development of electronics. Scientific and engineering journals, exhibition stands and shops received new models of electronic equipment, whose wide possibilities remained practically useless without improving loud-speakers.

«The bottleneck» of a loud-speaker is a flexible suspension responsible for the reproduction of multi-frequency. At that time nearly everything possible was „extracted” from materials.

Besides, a further increase of its flexibility and mildness lead to a contradiction... To solve this contradiction a transition to a new system was necessary.

*The problem solution: see Chapter 6: The law of transition to the supersystem. (Example 6.13)*

## Example



Take a close look at the growth of any plant coming from the ground. As a rule, it has two large leaves. Leaves are not proportionally large compared to the seed itself and a plant's stem. Under the ground the situation with a root system is the same. The reason is that a plant vitally needs solar energy and nutritive substances. In the course of development, other parts of a plant increase their growth rates and sizes compared to the initial ones.

## Example



The form of a child can be very well recognised even on a child's drawing: a human's body with an unproportional big head, short arms and legs.

A human body develops unevenly too.

- in the first 10 years of life a human experiences 70% of growth (the height of man);  
in the first 3 years of life a human receives 70% of absorbed information.

## Example



The development of social systems has an uneven character. Anatole France, the greatest France writer and publisher noticed very subtly and sharp-wittedly: „In a slow and well coordinated progress of a mankind the beginning of a caravan had already entered the shining fields of the science, when the tail was lagging behind among the heavy fog of superstitions, in dark land full of spirits and ghosts. Yes, you are right citizens if you go to the head of a caravan!..“

## 2.5.6. Self Assessment - (Questions, tasks)

### Resume



With the development of TS in time, TS undergoes some changes. Some subsystems are replaced by others, more efficient under certain conditions. External conditions, man demands change too. These changes accumulate, generate new conflicts between the parts of a system, other systems in the course of their practical use and improvement by man and provide new development possibilities.

This development does not occur evenly in time. Some parts of a system have the best parameters, others act as restraining force for the system's general development. Besides, meanings of the main parameters (that provide the performing of the TS functions) are also subject to *uneven* change in time.

### The Basic definitions.

Technical system (TS); ENV-model; element; name of a parameter; meaning of a parameter.





## Questions:

1. How is the development inequality of a system's parts expressed?
2. For what development stage of systems this law is more characteristic?
3. Is it possible to forecast the position of the point **a**) on the curve of the given technical system only on the basis of potential possibilities of TS itself, without taking into account the state of the preceding TS?
4. How does the complexity of a technical system affect the inequality of its development?
  1. With development, the parts of TS undergo modification according to the changing demands of man and environment. TS includes component parts of a different development level on various stages of its life. These inconsistencies can be described with the help of contradictions. Especially, sharp contradictions arise in the «weakest» part of a system, in a «bottle neck». (Theory (Details), page 1)
  2. The law belongs to the group «Kinematics», i.e. for advanced TSs that are on the second and third stages of developments. (See S-shaped curve). (Theory (Details), page 1)
  3. The existence of an old system holds back the appearance of young „competitors“. And only after an old system is gone, a rapid development of a new system begins (the bending point **a**). The stage «Maturity» comes in (Segment 2). (S-shape curve)
  4. The development of parts of a system proceeds unevenly; the more complicated the system, the more uneven the development of its parts. (Definition)

## 2.5.7 References

- Altshuller, G. S.** Creativity as an exact science. — M.: Soviet Radio, 1979. (Russian), Page 126.
- Altshuller, G. S.** (1984). *Creativity as an Exact Science: The Theory of the Solution of Inventive Problems* (A. Williams, Trans.): Gordon and Breach Science Publishers. Page: 229.
- Salamatov J.**, System of development of creativity laws. /In book: «Chance of adventure»/ Copiler. A.B. Selutsky. – Petrozavodsk: Karelia. 1991. (Russian). – Pages 110-112.
- Modis, T.**, Fractal aspects of natural growth Technological Forecasting and Social Change, 1994. 47 (1), p.63-73.



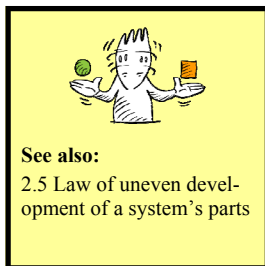

## 2.6 The law of transition to a super-system

If you ever happened to drink a hot, burning hot tea or coffee with the temperature of 65°C, you will hardly believe in the following fact.

The journal *Science* informed about a heat-resistant grass growing near to hot geothermal sources in Yellow Stone National Park (USA). The grass feels comfortable on the ground with the temperature of 65°C.

The researches conducted by biologists resulted in the discovery of a rare example of triple symbiosis in nature: a plant, a mushroom and a virus unite together in three in order to resist high temperatures.

In nature there are known cases of symbiosis, when plants or organisms group together, accommodate and support each other in order to survive.

The phenomenon of symbiosis, combination of various systems is also known in technology. Certainly, a direct transmission of the given phenomena from biological systems to technical ones would not be correct. However, it is curious to analyze some general regularity.

### 2.6.1. Definition

Having exhausted all development possibilities, a system is included in a supersystem as one of its parts; in doing so further development takes place at supersystem level.

Altshuller, G. S. (1984). *Creativity as an Exact Science: The Theory of the Solution of Inventive Problems* (A. Williams, Trans.): Gordon and Breach Science Publishers.), p. 229.



### 2.6.2. Theory (Details)

The law belongs to the group «Kinematics», i.e. the law is applicable for TS that are at the third stage of development (see S-shaped curve).

One of the ways of a system's further development which lies in the point **b** or **g** on a S-shaped curve (see Fig. 6.2.) is unification of systems. Thereby, unification of systems can occur earlier, on the segment 2, before the point **b** is reached. Such unification is possible in cases when there is at least one parameter which does not satisfy a user. Besides, it is necessary to perform a function in order to change this parameter; parts of another system can serve as resources of development.

A typical development chain of the line «mono-bi-poly» is described in the TRIZ literature. The initial system groups together with a system of the same type, of similar type, of different type or with an inverted system (with the opposite meaning of the function). The character of unification depends on the type of the required function. One of the main conditions of unification from the point of view of TRIZ is emergence of a new quality.

### 2.6.3. Model

S-shaped curve (see Chapter 5).

It is necessary to build a chart representing a time change of one of the system's main indicators. Thereby, we can use patent fond and other sources that reveal the preceding development of a system to be analyzed. Furthermore, with the help of a received S-shaped curve it is possible to draw conclusions about the stage of development on which TS is situated at the given moment.

If results of the analysis show that TS is near to the point **b** or to the point **g** and there is a further necessity to increase the main parameters, it is necessary to define a new technical system that must change an existing one. One of such systems change is transmission of existing TS to the composition of a new, more advanced system.

A combination of systems can take place at any stage of development. It is necessary to define the required function of a system.

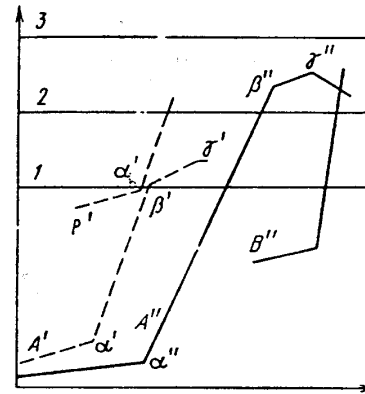

Fig. 6.2

## 2.6.4. Instruments - Tools (how to use)

### Example

So, by combining two knives, mankind invented principally a new cutting tool: scissors.

*Instruments of solution:* Tools of laws – the law of fullness of system's parts; the law of power conductivity; the law of rhythmic adjustment.



### Example

Just by putting some pencils of the same type on the table, we do not receive a new system or a new quality. However, we can change one of the parameters: time of writing without extra sharpening a pencil, but replacing e.g. a blunt pencil by a new one while writing. Thus, we perform a new function.

Ordinarily, when we put several pencils with the different thickness of a pin on the table in front of us, we can change one of the parameters – a period of writing without any additional sharpening of a pencil (a change from one pencil to another, from a blunt pencil to a sharpened one in the process of writing). And that means that we can provide the fulfilment of a new function: to write letters on a sheet of paper without any pauses used for the sharpening of a pencil.

*Instruments of solution:* transition monosystem-polysystem with characteristics of the same type.



### Example

Another way of combining writing tools was used by Leonardo de Vinci who created the device which made copies. Two writing pins made of lead were bounded on the ends of «flyer» in the form of a letter «Y» with a common pen. While writing a text with such a double pencil, an author received two copies of a document at the same time. (However, a secretary had to write on narrow stripes of paper; the width of which was limited by the space between the branches of a letter «Y»).

*Instruments of solution:* transition mono-system – bi-system with characteristics of the same type.



### Example

As it was already pointed out, systems with slightly differentiating characteristics can be grouped together. In TRIZ they are called „systems with adapted characteristics“. To make notes with pencils of different colours for the purpose of convenience, two pencils - on the one hand, a red pencil and a blue pencil, on the other hand - were combined in one.

*Instruments of solution:* transition mono-system – bi-system with dislocated characteristics.



## Example



Systems with inverse characteristics can be grouped together too. One function «To leave a footprint on the surface» can combine with an inverse function «to remove a footprint on the surface». This can be a combination of a pencil with an eraser or a pen with a correction fluid.

*Instruments of solution:* transition mono-system – bi-system with inverse characteristics.

## Example



Several systems can group together in one system. We know such systems. The example of such a system is a pen with several writing pins of different colours.

*Instruments of solution:* transition mono-system – bi-system with dislocated characteristics, convolution.

## Example



Further development of a system which entered into another system takes place on the level of the whole system. As a system develops, the degree of ideality grows. One of the ways of such process is exclusion of parts duplicating each other from the system. Thus, only one common frame remained while grouping together several coloured pencils into one writing tool since frames of every pencil were left out because of uselessness. In OTSM-TRIZ such operation is called «convolution».

*Instruments of solution:* Convolution

## Example



Further development of a system can take place with the rolling-up of writing tools. So, to draw lines of different thickness it is necessary to have a set of several pins in one frame. We know a carpenters' pencil with a lead of a square section. Such pencil can make either thin lines when using a narrow side of a lead or wide lines when using another side of a lead.

*Instruments of solution:* Convolution; geometric effect.

## Example



A marker with a section of a writing pin in the form of ellipse was suggested. Such marker can be used to draw lines of different thickness – from a small to a large diameter of ellipse. Thereby, thickness of a line can be changed without taking away a marker from the paper. It is sufficient to turn a marker around its axis.

*Instruments of solution:* Convolution; geometric effect.

## 2.6.5. Example Loud speakers

### Example



Two or three loud-speakers are placed into the frame of a loud-reproducing device or a sound column in order to extend the range of reproducible frequencies. One of the loud-speakers reproduces low frequencies (basses) well, but badly high frequencies. Another loud-speaker, on the contrary, badly transfers low frequencies, but instead reproduces high frequencies well. However, the solution to place several loud-speakers into the frame of a loud-reproducing device has a substantial disadvantage: it requires much additional space and volume. Devices equipped with two and three loud-speakers have a large weight. The inventor Shifman suggested a loud-speaker that combines two different devices in itself: high-frequency and low-frequency of loud-speakers. It has one magnetic system, one frame, but two coils and two diffusers. Diffusers are located concentrically, i.e. one diffuser inside of another diffuser. In TRIZ such solution is called a bi-system.

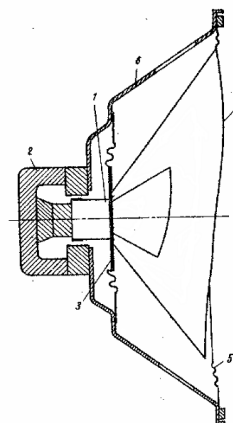

Fig. 6.3

## Example

Every loud-speaker that constitutes a bi-system in the previous example has its own range of frequency reproduction. We can go further, following the regularity «mono-bi-poly» and coaxially place not two, but three diffusers into one frame. But in this case the construction of the whole device as well as the manufacturing technique will become substantially complicated. It is a rather difficult technical task to manufacture separately and coaxially set up several different cone-diffusers and several coils located coaxially.

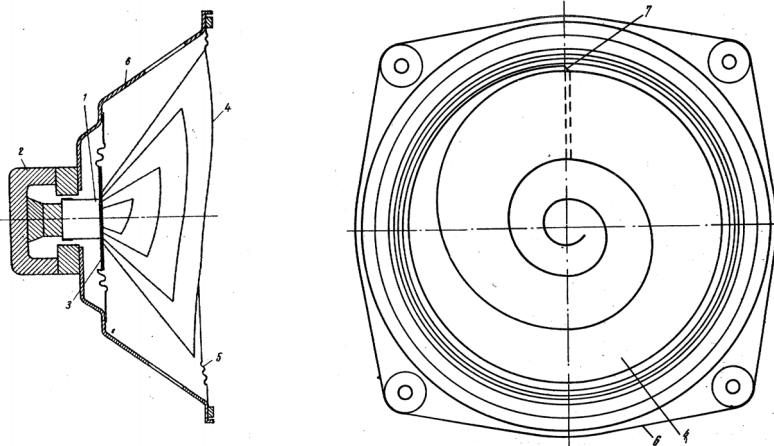

Fig. 6.4.

The inventor G.I. Gelfenstein elaborated a loud-speaker with 3-4 diffusers and one coil. The number of diffusers can be increased. A diffuser is made in the form of an Archimedes spiral with a required amount of whorls and one coil. Every whorl serves as a separate diffuser-transmitter of sound. Every whorl exists on its own and simultaneously constitutes one single system. A whorl-diffuser has its own mass and elasticity and that means it its own certain frequency characteristics.

When an electrical signal of a certain frequency is transmitted to the coil, whorls-diffusers corresponding to this frequency according to their characteristics begin vibrating. In other words, diffusers turn on at the frequency fed to the coil by THEMSELVES. So, when low frequencies (basses) are fed, the whole diffuser consisting of several whorls will begin vibrating as single system. The higher the fed frequency of a signal is, the smaller number of whorls will be brought into vibrations. At high frequencies only the centring part of whorls will send out a sound, the remaining part of a diffuser will not respond to «unfamiliar» frequencies and remains unmoved.

In TRIZ such solution of combining several systems of the same type is called a convoluted poly-system.

## Example

Not only one loud-speaker can be grouped together with another one as it was described in previous examples. A loud-speaker can be combined with...emptiness. However, this emptiness is deceiving since the air has a mass.

And that means that it has also its own elasticity.

A loud-speaker is one of the subsystems of many devices for sound reproduction. It is established in radio receivers, tape-recorders, TV-sets... The frame of every of these devices has its own volume.

The first stage of combination with a supersystem, i.e. with the frame of a device (a radio receiver, a TV-set) is a simple mechanical combination. The frame combined and comprised all subsystems: a mechanical part, an electrical device and an acoustic system.



The second stage: air volume «worked» for a loud-speaker but was not adjusted with it.

The third stage: to adjust air volume of an acoustic system with a loud-speaker in order to reach higher values of the main parameters. (for more details see the following example)

## Example

To extend the range of reproducible frequencies loud-speakers were placed in closed boxes of a large volume, i.e. column speakers. Such technical solution enables to substantially reduce the low border of a reproducible range and improve reproduction of basses.



However, there arises another contradiction. «The volume of a column speaker must be large enough to reduce the resonating frequency of an acoustic system; and the volume of a column speaker must be small enough to be able to conveniently place it in rooms». This problem lies on the surface. However, as it was already pointed out the main problem is unlinear distortions which the vibrating system of a loud-speaker introduces. We consider the described situation in a quite simplified way. To understand a dramatic nature of the situation in which acousticians found themselves, we have to describe it in the form of a network of problems.

Nevertheless, the inventor Vilchur chose intuitively the main contradiction. The vibrating system of a column speaker, i.e. a centring plate and flute is nothing else like a spring. Any spring at the sufficient amplitude of vibrations is a nonlinear element which is responsible for sound distortions.

Thus, «a spring is necessary to perform vibrations; and no spring is necessary to exclude nonlinear distortions».

Note:

The example is interesting since it shows several laws.

- The Law of transition to a micro-level: replacement of a mechanical spring by an air one;
- The Law of ideality increase: an air spring is more ideal and has a smaller nonlinearity than a mechanical spring;
- The Law of transition to a supersystem: combination of a loud-speaker with an internal air volume of a sound column.
- The Law of rhythmic adjustment: adjustment of the resonating frequency of a loud-speaker and the air volume of a box.

IER (Ideal End Result): There is no spring-vibrating system, but the function to perform vibrations is retained. Vilchur replaced the part of the vibrating system of a loud-speaker, i.e. mechanical suspension by an air spring. An improved loud-speaker had a very soft vibrating system with a maximum possible resonating frequency. However, it did not function properly when it was separated from a sound column. Its suspension (a centring plate and flute) was so soft that required additional support to be able to maintain a normal position. Such support, i.e. the main spring was the internal volume of air inside of a sound column. Being placed in the sound column, such loudspeaker created new TS together with a sound column, i.e. a vibrating system that had desired characteristics: a low resonating frequency and large amplitude of vibrations (and acoustic pressure).

## 2.6.6 Self Assessment - (Questions, tasks)

### Resume.

The law of transition to a supersystem belongs to a TS that has exhausted all possibilities of its development. Under these conditions the next stage of a system's development is its transition to a supersystem as one of its parts. Further existence and development of a system takes place on the supersystem level.

### The Basic definitions.

System, super-system, subsystem, symbiosis; rolling-up, mono-system; bi-system; poly-system.



## Questions:

How is the law of transition to a super-system expressed?  
For what development stage of technical systems this law is more characteristic?  
Give some examples which illustrate the law of transition?



## 2.6.7 References

**Altshuller, G. S.** Creativity as an exact science. — M.: Soviet Radio, 1979. (Russian),  
Page 126.

**Altshuller, G. S.** (1984). *Creativity as an Exact Science: The Theory of the Solution of Inventive Problems* (A. Williams, Trans.): Gordon and Breach Science Publishers.).  
Page: 229.

**Salamatov J.**, System of development of creativity laws. /In book: «Chance of adventure»/ Copiler. A.B. Selutsky. – Petrozavodsk: Karelia. 1991. (Russian). – Pages 124-138.

**Luis M. Márquez**, Regina S. Redman, Russell J. Rodriguez, Marilyn J. Roossinck.  
A Virus in a Fungus in a Plant: Three-Way Symbiosis Required for Thermal Tolerance // *Science*. 2007. V. 315. P. 513–515.

**Chubinsky G.**, Net of paladins. Moscow: Veche, 2008. (Russian). – P. 448.



## 2.7 The law of the transition from the macro to the micro level

What are the reasons of the appearance of earthquakes on the Earth?

One theory dominates in the scientific world, which explains the origin of earthquakes as a result of the collision of tectonic plates. According to the theory of tectonic plates the surface of the Earth (the Earth's crust) is divided approximately into 20 separate pieces named plates. Their thickness is approximately 70 kilometres. Under the influence of the processes occurring inside of the Earth, plates move. Movements are insignificant, but cause very big mechanical pressure on the Earth's crust, and as consequence – earthquakes. However, as a result of seismic observations, the incredible facts have been observed.

Fact 1: When some earthquakes took place, tectonic plates did not collide with each other, but dispersed into different directions.

The fact 2: in accordance with the results of the analysis of some seismic waves, the conclusion has been drawn that the tectonic plate moves in opposite directions, whereas it is known from other observations that it represents a unified whole and does not consist of smaller parts.

The fact 3: sources of some earthquakes are not located in the place, where the collision of tectonic plates takes place – not on their borders, but they are found inside of a plate block.

The easiest way of solving this problem is to wave away from the contradictory facts and to realize that there were wrong observations and calculations... Actually, it is a signal that the recognised theory has approached to its limit behind which it does not work any more. It is a signal to create a new theory.

The macro-objects- tectonic plates were considered to be the «Tool» of generated earthquakes in the old theory. A number of researchers had suggested a hypothesis about the possibility of the generation of earthquakes as a result of complex interactions of oscillations in the structure of the Earth – mechanical waves. According to the new theory the micro-objects can serve as the "Tool" which causes earthquakes. These micro objects are oscillations of particles of the Earth's crust which are described by various types of waves.

On the basis of the contradictory facts which were received during the observation and in terms of the suggested hypothesis the new theory is developed- the wave theory which explains the causes of earthquakes.

The special type of the mechanical oscillations has been already determined – stationary waves, which are responsible for earthquakes without the collision of tectonic plates in every spot of the Earth.

The European model of waves which deals with the structure of the Earth is developed and the global model will be developed in the perspective.

We can draw many striking conclusions from this theory. One of them – tools of technical systems are transited from the macro to the micro level in the course of its evolution. It often refers to our visualization about the world – models of different processes and phenomena. A human-being gets closer to the mechanism of Nature in the course of learning.

### 2.7.1. Definition

The development of working organs ("Tools") proceeds at first at macro and then, at a micro level.

Altshuller, G. S. (1984). *Creativity as an Exact Science: The Theory of the Solution of Inventive Problems* (A. Williams, Trans.): Gordon and Breach Science Publishers., p. 230





## 2.7.2. Theory (Details)

In the majority of the modern technical systems the working device (Tool) is «pieces of iron», parts in the form of micro-objects, which reminds often the hands of a human-being.

The Tool is changed at first – as a result of the new necessity to perform the new function.

As a rule, the mechanism of the Law of transition from the macro to the micro level can be used to solve the contradictions of the Tool. So, at transition of the Tool to micro-level the space and the volume occupied by the Tool and the technical system decreases; its efficiency increases; its multifunctionality increases.

This transition is often performed by the new principle of the work, by the new physical, chemical, geometrical effect or by the phenomenon. For this reason the practice of the application of the law is closely connected with other tools and technologies OTSM - TRIZ: ARIZ, Standards, Methods, the Multiscreen scheme and others.

## 2.7.3. Model

The models which illustrate the law of the transition from the macro level to the micro level include the following elements:

- the multi-screen scheme;
- S-shaped curve;
- the line of development of «the mono-bi-poly chain»;
- the list of typical fields which are used in the technical system;
- a split chain of substance;
- and others.

Let us illustrate one of them – a split chain of substance.

There appear the following stages of development in the course of evolution of a part of the technical system:

1. a monolithic system;
2. a system with a joint;
3. a flexible construction;
4. particles; small particles (fine particles); granular materials;
5. molecular aggregates, molecule, atoms, ions;
6. elementary particles,
7. a field.

This model of development has a generalised character. The stages of development are illustrated in the close view. If necessary it is possible to examine "Line" in more details. For example, the stage «System with the joint» can be developed in some sub-stages: «the system with one joint», «system with two joints» etc.

Logic of its application requires not only the obligatory and the unconditional transition of a system to the next stage of development in accordance with the split chain. The main condition of the necessity for the transition is the requirement for the performance of the new function, on the one hand and impossibility of its performance by the given technical system, on the other hand, to be more precise, the presence of a problem, the administrative and the technical contradiction. The means providing the possibility of such a transition are the revealed physical contradiction and the way of its decision which corresponds to one of transitions of «a split chain».

It is very important to know and constantly to remember about the split chain. But on the other hand, it should be applied not mechanically. It is important to analyze a technical system; the evolution of its development; arising problems. It is necessary to define correctly the function which is demanded from the technical system. And only after that to apply «the split chain» and other tools of OTSM-TRIZ.

A lemma. (Lemma) – the assumption applied without the proof owing to its obviousness.

For the technical system (TS) or its parts there will be at least one function which the given TS is not capable to perform. It is necessary to change the given TS or its part in accordance with one of its transitions through «a split chain».

## 2.7.4. Instruments - Tools (how to use)

At a stage of posing a problem.

During the practical application of the given law it is necessary to define that stage of development where a Tool of a system (a working body) is found. To estimate, whether there is a limit of its development. Whether there are alternative systems which have the micro-level structure.

At a stage of the solution of a problem.

During the search of the solution to a problem, it is necessary to pay attention to physical, chemical, geometrical effects and the phenomena, which give the possibility of the transition to the micro level.

The law of the transition from the macro to the micro level works often together with other laws. For example, the law of “energy conductivity” of parts of the system; the law of harmonizing the rhythms of parts of the system; the law of increases of Su-Field. So, the criteria which are put forward by the laws of “energy conductivity” and the law of harmonizing the rhythms of parts of the system can be reached, when the transition from the macro to the micro level is completed. And the mechanisms of the law of increase of Su-Field can serve as the transitional method from the macro to the micro level.

Illustrations of «a split chain» are shown in the example of a subsystem of "wheel" of means of transport.

### 1. the monolithic system:

A monolithic wheel made of such materials as stone or tree.

### 2. a system with the joint:

A joint is used to complete the function of the wheel turn;

### 3. a flexible construction:

A wheel with the rubber coating (surface);

The change of the part of the solid massive of the wheel into spokes;

A track of the tractor or the tank;

A flexible gear (which adopts to the ground contour);

### 4. particles; small particles; granular materials:

a wheel with air cell chamber;

a construction of the type - brush;

a water-jet motor;

a reluctance motor;

### 5. molecular aggregates, molecules, atoms, ions;

Air flow («air cushion»);

The ion engine (this idea is described in the science fiction literature);

### 6. elementary particles.

The «solar sail» (the idea is described in the science fiction literature);

### 7. A field

The magnetic cushion (the trains "Transrapid" and "MAGLEV" – Magnetic Levitation);



## 2.7.5. Examples

### Example

Let's consider briefly some examples from the history of the record and the storage of a sound for its subsequent reproduction.

The first technical devices for this purpose were: a striking clock with various melodies; the mechanical piano; a street organ. It should be noticed at once that it is not actually the recording of a sound, but its programming. The carriers of the sound information in such a system are: the succession of teeth, hollows, ledges on a rotating shaft, on a wheel.

Besides, the strings, vibrating plates, etc. are necessary for reproduction of the sounds which are «recorded» in such a way. The size of all these elements for the record and the reproduction of a sound fluctuates from millimetres (in a pocket watch) to several centimetres and to tens centimetres in a tower clock.

The size of an element of the storage of a sound: 0,1 mm – 10 cm.



### Example

The sound recording has actually begun with the invention of a phonograph performed by Edison. Mechanical fluctuations of a recorded sound left a trace on the wax rotating platen. This "trace" of a sound was transferred then on the firmer basis – metal, and then, on the plastic basis. An element which preserves a sound recorded was the variable sound track (groove) which is created by a sound itself. The size of this element varies in millimetres. The sizes of an element of the storage of a sound have decreased in comparison with teeth, hollows, and strings.

The size of an element of storage of a sound: 0,01 mm – 0,1 mm



### Example

With the transition to a magnetic way of a sound recording there were new technical systems – tape recorders. Originally, the record was performed on a thin, metal wire, then – on a plastic recorder tape with the dust, ferromagnetic powder. In these cases magnetic particles and magnetic domains became the carrier of sound fluctuations which sizes vary in 1-10 micron. The size of the element which stores sound fluctuations has decreased by several times. The size of an element of the storage of a sound: 0,001 mm – 0,01 mm (1-10 micron).



### Example

Now optical disks, stores on magnetic disks, solid-state elements (crystals) serve as the data carriers and are used for a sound recording. The apertures in optical, laser disks; magnetic structures – domains in magnetic stores; nanostructures in electronic chips are used as a storage element in such systems. The sizes of elements of the storage have decreased by several times in comparison with the previous example.

The size of an element of the storage of a sound: fractions of a micron.

We intentionally consider the evolution of development of means of the record and the sound storage simply, passing many details and sketching the technology only in general. The aim of this consideration is to show the transition of elements of the storage of the information from the macro-level to the micro-level.



### Example

What constrains the further increase in speed of trains? The problems appear, when a train moves at high speed and there is the contact of a wheel with a rail.

The next stage of development of a train – a train on an electromagnetic cushion bolster instead of usual wheels. The transition from the pair "wheel-rail" to the electromagnetic interaction is carried out in the construction of this train. This kind of transition has solved some problems: smoothness of movement, noise decrease, a transmission of energy from the source to the train



engine. The current collection (transfer) has also undergone changes –there is no sliding contact "current collection-wire" in it. The function of the transmission of energy is also carried out by means of a field.



Fig. 7.2. "Transrapid" train.



Fig. 7.3. Speed indicator for passengers.

## 2.7.6. Self Assessment - (Questions, tasks)

### Summary.

The «Tool» of many technical systems is the macro object. Its development is performed at first at the macro level. Later on, after the resources of its development are exhausted, the Tool is transferred to the micro level.

### The basic definitions.

Micro level; Macro level; multi-screen scheme; S-shaped curve; line of development of «the chain mono-bi-poly»; list of typical fields, which are used in the technical system; the split chain of substance.

### Questions:



1. How can we define the transition from the macro to the micro level?
2. What are the main conditions of the change of the Tool and its transition from the macro to the micro level?
3. Give some examples of the transition from the macro to the micro level.

## 2.7.7. References



- Altshuller, G. S.** Creativity as an exact science. — M.: Soviet Radio, 1979. (Russian), Pages 126-127.
- Altshuller, G. S.** (1984). *Creativity as an Exact Science: The Theory of the Solution of Inventive Problems* (A. Williams, Trans.): Gordon and Breach Science Publishers.). Page: 230.
- Salamatov J.**, System of development of creativity laws. /In book: «Chance of adventure»/ Copiler. A.B. Selutsky. – Petrozavodsk: Karelia. 1991. (Russian). – Pages 112-124.



## 2.8 The law of increasing the S-field involvement

A wonderful photo of a wolf lies in front of me: a careful and cautious look of the clever eyes, fearful fangs in a rapacious grin and muscles are strained before a decisive jump. But it is rather cleverness and inventiveness that attracts me most of all in these animals. We can draw many analogies and parallels in the evolution of biological and technical systems. There is even a science called bionics that studies possibilities of application of biological solutions in technology.

We are not interested in solutions, but primarily in methods of solutions. Here is a task. Even children know that a wolf eats a raw meat and does not brush his teeth. Those who have ever seen a wolf in a zoo know what unpleasant and strong smell comes from the animal's mouth. However, it is his smell, the smell is natural for him and even serves as its „business card” while meeting and communicating with other wolves.

But this smell can disturb a wolf. Often a wolf attacks its prey from a cover, ambush. He crawls towards the habitat of its prey from the downwind side - so that the wind blows from the side of a prey in direction to a wolf and not the other way round. In this case a wolf smells an animal it hunts for and the smell of a wolf is carried away in the opposite direction.

But what is the way of acting in windless weather or when the distance to a prey is very short? This problem is especially acute in winter. Smells from the heated breath of a wolf in the cold air spread out very well. There are no masking scents of flowering plants and other manifestations of the nature. Everything has died out till the spring comes again...

A wolf stands still in his ambush too. He does not brush his teeth, neither knows he the way to solve the task. He is guided by a powerful, centuries-old instinct, experience and knowledge of his ancestors and his personal experience and mind. Very often the price of ignorance and non-observance of rules is his life, life of his offsprings....

That is why before a decisive jump at a prey, a wolf takes a full mouth of... snow at his winter ambush! Snow reduces the temperature of a wolf's mouth and evaporation of moisture, i.e. his smell for a while. Besides, this natural filter from a variety of small snow crystals has a large surface and keeps down smells. Finally, snow melts in a wolf's mouth and water takes away smells with itself, without giving them a chance to spread out in the air. If the time for a convenient moment to attack a prey lingers, a wolf takes a full mouth of snow again and again...

What has changed in the structure of a system? For the sake of brevity we give only a S-field formula of a conflicting part of the system «wolf-prey» before and after introducing the change «snow in the mouth to eliminate a smell». For a more detailed explanation of the tool see Chapter «Examples».

Problem:

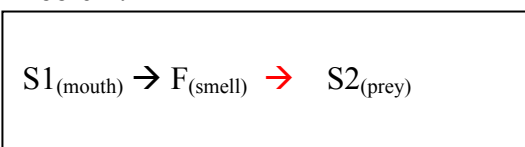

Solution:

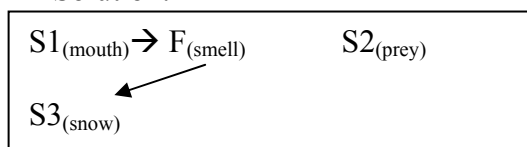

## 2.8.1. Definition

“The development of technical systems proceeds in the direction of increasing the S-Field involvement”.

Altshuller, G. S. (1984). *Creativity as an Exact Science: The Theory of the Solution of Inventive Problems* (A. Williams, Trans.): Gordon and Breach Science Publishers., P. 231.



## 2.8.2. Theory (Details)

We know already that parts of a technical system develop unevenly in the course of the evolution of a TS. At certain development moments one of the parts of a technical system becomes complicated. But this complication, this development can be logically explained.

That part of a technical system undergoes development (in a particular case: gets complicated) which comprises a conflict, technical and physical contradictions. Correspondingly, a S-field model reflects exactly this situation. In this case we can speak about the direction of TS development that a S-field model reflects as increasing of S-field involvement.

To describe a simple technical system tool, a S-field consisting of 2-3 elements is sufficient. As a rule all technical systems at the stage of generation are a product that is processed with a tool by using manpower. It is simple instruments of labour like a spear, a knife and so on. Gradually, drawbacks of this technical system come to the fore, new needs and solutions regarding the change of the initial technical system to satisfy these appeared needs.

In the course of changes of the initial technical system, a technical system reveals new subsystems with its drawbacks which require solutions in regard to their improvements.

To analyze and identify problems and ways of their solution, it is necessary to clearly demonstrate the structure of a technical system, a conflicting zone, i.e. a „bottleneck” as well as changes that take place in this structure as the technical system develops. It becomes possible with the use of a S-field model.

## 2.8.3. Model

A technical system can be described as a S-field. This model consists of the main fields and substances of a technical system and its interconnections. Not all fields and substances which are present in a technical system are included in the model, but only those that directly work to achieve the function of a technical system.

$S1 \rightarrow F \rightarrow S2$

Let us take an electrical kettle for water heating as an example. The function of this technical system is to heat liquid (water) from the initial temperature (a room temperature) up to the boiling temperature». Or: «to change the parameter of the element WATER from the Value «a room temperature» to the Value «boiling temperature». In this case the S-field formula is:

S1 – electrical heater of a kettle;

F – Thermal field;

S2 – water in a kettle.

The formula means: electrical heater of a kettle S1 heats water to the boiling temperature with the help of a thermal field F.

A S-field model of an electrical kettle can be unfolded in a more detailed and wide model depending on objectives of the analysis. For instance, if we want to analyze, identify and describe problems connected with the transformation of electrical energy into thermal one, we have to build a S-field. In this case a S-field formula will be complemented by an element: «field of electrical power».

F(electricity) à S1(spiral) à F(heat) à S2(water)

## 2.8.4. Instruments - Tools (how to use)

It is possible that the given technical system will not meet a customer's needs. For example, we can be dissatisfied with the operation mode of a kettle. By turning on a kettle into an electrical power network, water in a kettle will be brought to the boil, afterwards water will convert into steam until water steams away and the spiral of a heater burns out. Let us specify a required new function for us. When the boiling temperature of water is reached, a kettle has to be turned off automatically.



A possible partial solution is reflected in a new S-field formula. In a TS a new substance S2 is introduced (for instance, a bimetallic plate that bows when reaching the temperature of 100° C, i.e. a steam point and unlocks contacts of a spiral-electrical heater).

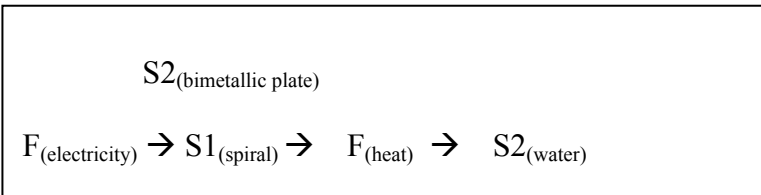

## 2.8.5. Example

### Example

Let us consider the example with a wolf from the point of view of a S-field analysis in a more detailed way.

The problem is that a prey can perceive the smell of a wolf at a short range:



$$S1_{(\text{mouth of a wolf})} \rightarrow F_{(\text{smell})} \rightarrow S2_{(\text{prey})}$$

What is the way of keeping back, eliminating the smell that comes from a wolf's mouth? It is necessary to destroy a harmful connection in order to perform a hidden function:

$$F_{(\text{smell})} \rightarrow S2_{(\text{prey})}$$

It is necessary to build a S-field by introducing a new field or a new substance:

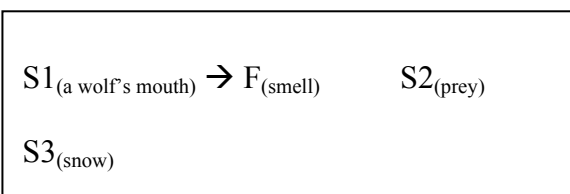

The conventional names are given to substances and fields. The purpose of these names is to improve understanding of the situation. In fact, chemical substances in a wolf's mouth serve as a source of the smell. From a physical point of view a smell field is volatile chemical compounds

which reach another animal through a wolf's breath. Substance-2 marked as «prey» in a detailed consideration is receptors of sense of smell. However, for analysis it is more important to create a mental image of a S-field. An integral perception of a situation is more important than details and precision of definitions.

### Example

How to pull small items (for instance, metal fillings) out of a deep hole? It is difficult to do that with the help of mechanical tongs. In the formula of a S-field it is expressed in a bad interaction of a mechanical field with fillings:



$$F1_{(\text{mechanical})} \rightarrow S1_{(\text{fillings})}$$

Let us complete building of a S-field by introducing a new substance (magnet) and a new field (a magnet field): F1<sub>(mechanical)</sub> → S2<sub>(magnet)</sub> → F2<sub>(magnet field)</sub> → S1<sub>(fillings)</sub>

How to solve this problem, if fillings are not magnetic? The logic of the solution is the same, but it is necessary to select a field that has a good interaction with fillings. It can be an adhesive substance and power of mechanical adhesion (mechanical field) with fillings, for instance.

$F1_{(mechanical)} \rightarrow S2_{(adhesive\ substance)} \rightarrow F2_{(mechanical)} \rightarrow S1_{(fillings)}$

## Example

Figure 8.1 below shows a section of magnetic chain of a loud-speaker.

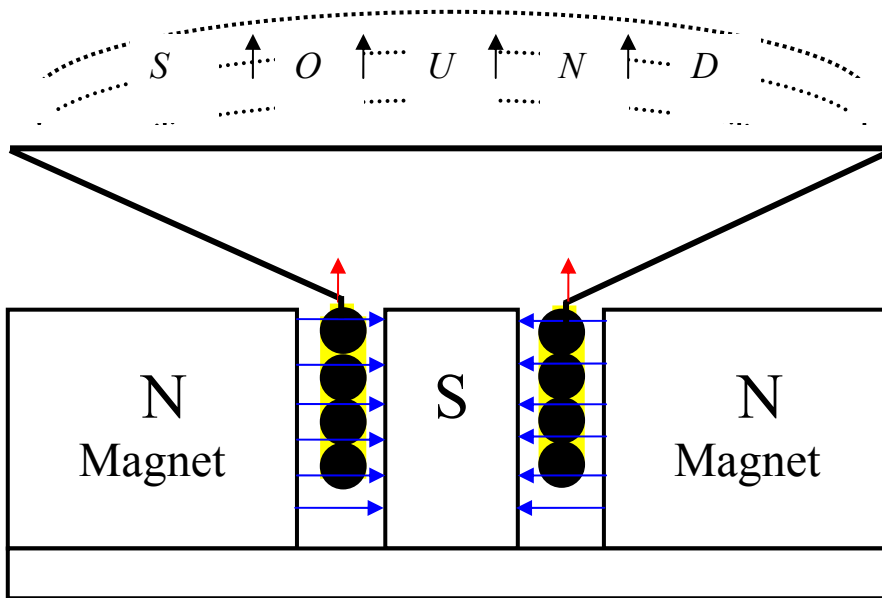

*Fig. 8.1. Section of a magnetic chain of a loudspeaker*

Legend:

- 1 – magnet
- 2 – compound that performs the function of a coil frame
- 3 – a coil
- 4 – diffuser
- 5 – lines of a magnetic field

A coil with a conductor which is in a magnetic field is «engine», transformer of electric and magnetic fields into mechanical vibrations of a diffuser and afterwards of the air.

Earlier (Chapter 2, example 2.2, task at the end of section and Chapter 4, example 4.5.) we have already considered a magnetic chain of a loud-speaker.

After replacing a coil frame by a compound which fastens whorls of a coil it became possible to improve the cooling of a coil, and reduce the gap of a magnetic chain. However, to reduce losses in a magnetic chain and increase the efficiency of the whole technical system «Loud-speaker», it is necessary to reduce the distance between magnets. The larger gap, the more losses there is.

Thereby, a new contradiction appears: the gap must be small to reduce losses in a magnetic chain; the gap must be large to improve the cooling of a coil. Ideally, there must be no air gap in a magnetic chain.

We can consider various situations with the help of a S-field analysis:

- model of a technical system while performing the main function;
- model of a technical system while performing the main transformation of energy by



«Engine»;

- conflict-1: energy losses in the gap;
- conflict-2: coil cooling;
- and others.

Let us consider the situation with losses in the air gap of a magnetic chain. We point out a contradiction: there must be an air gap in order to provide a free movement of a coil; there must be no air gap in order to avoid losses in a magnetic chain.

Let us build a S-field formula of this conflict:

$$S1_{(\text{magnet})} \rightarrow F_{(\text{magnetic})} \rightarrow S3_{(\text{air gap})} \rightarrow S2_{(\text{coil})}$$

The given contradiction can be formulated in the following way: a gap between magnets must be continuous to be magnetic; the gap must not be continuous in order to allow moving of a coil.

The given contradiction is solved by a breakdown of a S-field by introducing a new substance in a gap, an air gap of a magnetic chain:

$$S1_{(\text{magnete})} \rightarrow F_{(\text{magnetico})} \rightarrow \cancel{S3_{(\text{traferro})}} \rightarrow S2_{(\text{bobina})}$$

We get the following S-field by replacing an air gap by a magnetic liquid:

$$S1_{(\text{magnete})} \rightarrow F_{(\text{magnetico})} \rightarrow S4_{(\text{liquido magnetico})} \rightarrow S2_{(\text{bobina})}$$

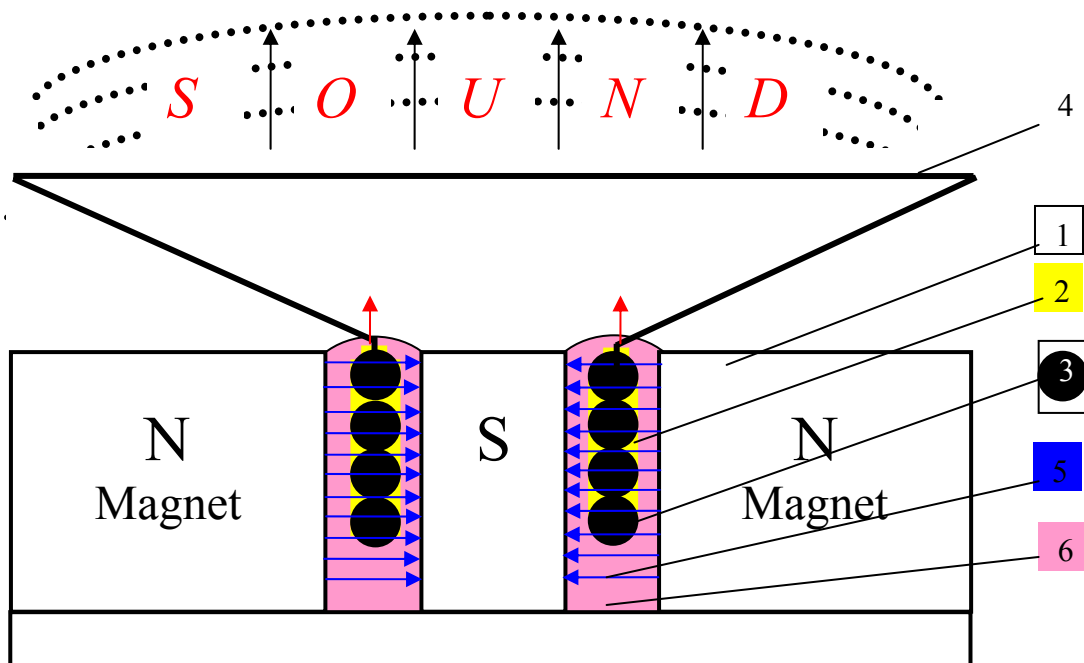

Fig. 8.2. Section of a magnetic chain of a loudspeaker with a gap filled by a magnetic liquid (6)

Legend:

- 1 – Magnet
- 2 – Compound that performs the function of a coil frame
- 3 – A coil
- 4 – Diffuser
- 5 – Lines of a magnetic field
- 6 – Liquid magnetic material

A magnetic liquid is very small particles of a magnetic material which is in a suspension state in liquid. Such mixture has properties of two substances: on the one hand, it is magnetic. On the other hand, it has the property of liquid, i.e. it is fluid. Thus, by filling the gap, a magnetic liquid reduces energy losses, but enables a coil to move freely.

The given solution with the introduction of a magnetic liquid into an air gap allows solving one more important problem: a coil cooling. By reducing the gap in order to decrease magnetic losses, we worsen the removal of heat from a coil. It is known that air has a very low heat capacity and a bad thermal conductivity. That is why by decreasing its volume in the gap, we reduce the amount of removed heat. Its replacement by a magnetic liquid enables to transmit heat from a coil to the environment more efficiently.

moment to attack a prey lingers, a wolf takes a full mouth of snow again and again...

## 2.8.6. Self Assessment - (Questions, tasks)

### Resume.



A technical system and its part can be represented in the form of a S-field model. A S-field model represents substances and fields which are included in the given TS or its part used to perform the described function as well as interconnections and their character between substances and fields of the given TS or its part.

The development of technical systems proceeds in direction which is reflected in change of a S-field model. These changes take place in direction of increasing of S-field involvement. In particular: the increase of a number of elements (substances and fields); the increase of the amount of connections between elements; the increase of sensitivity of connections between elements; introduction of new elements; change of the structure of a TS.

### The basic definitions.

S-field, a S-field model, substance, field

### Questions:

What is a S-field model?

What is the law of increasing of S-field involvement?

Give examples to manifest the law of increasing of S-field involvement.



## 2.8.7. References

**Altshuller, G. S.** Creativity as an exact science. — M.: Soviet Radio, 1979. (Russian),  
Page 127.

**Altshuller, G. S.** (1984). *Creativity as an Exact Science: The Theory of the Solution of Inventive Problems* (A. Williams, Trans.): Gordon and Breach Science Publishers.).  
Page: 231.

**Salamatov J.**, System of development of creativity laws. /In book: «Chance of adventure»/ Copiler. A.B. Selutsky. – Petrozavodsk: Karelia. 1991. (Russian). – Pages 103-110.

**Kaikov O.I.**, A few examples of problems and solutions taken from wolves' life and behavior. – Karlsruhe, 2008. (Manuscript).



# tETRIS